

DETAILS OF JOINT HARNESS
SCALE 1:10

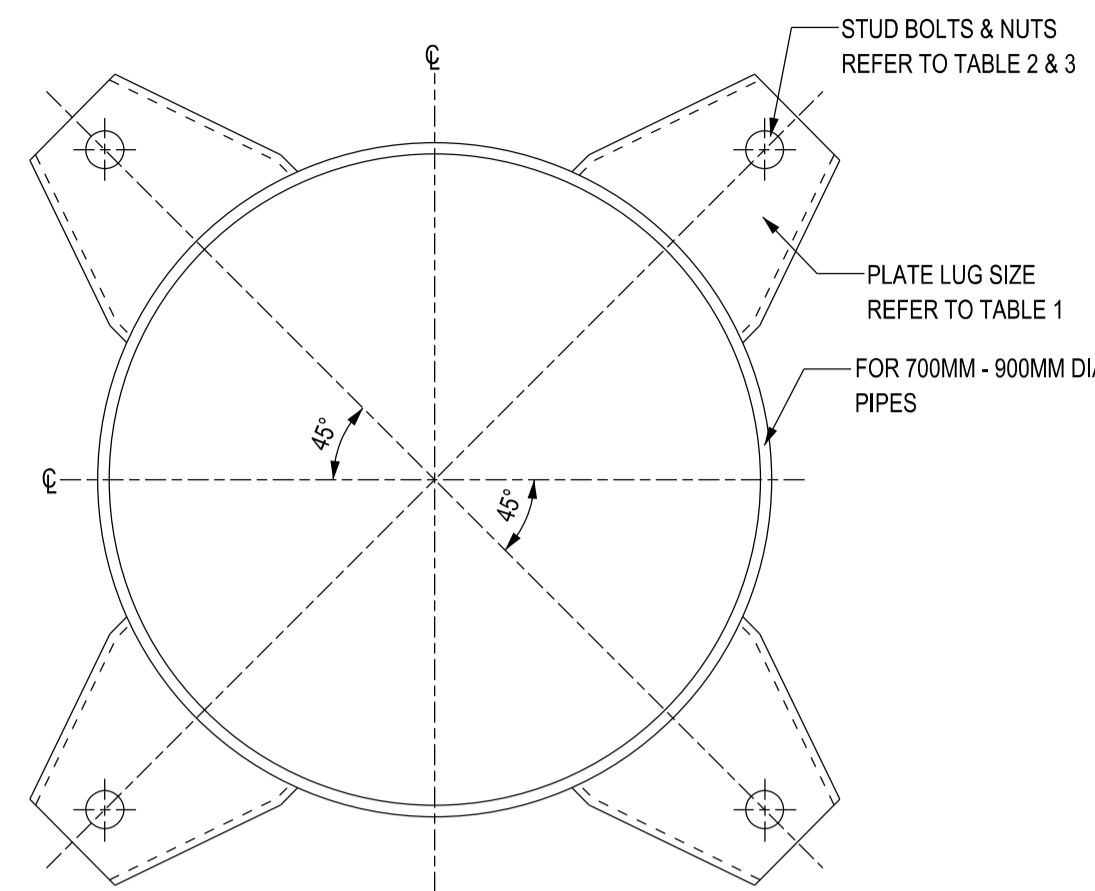

SECTION A-A
FOR 700MM - 900MM DIA PIPES
SCALE 1:10

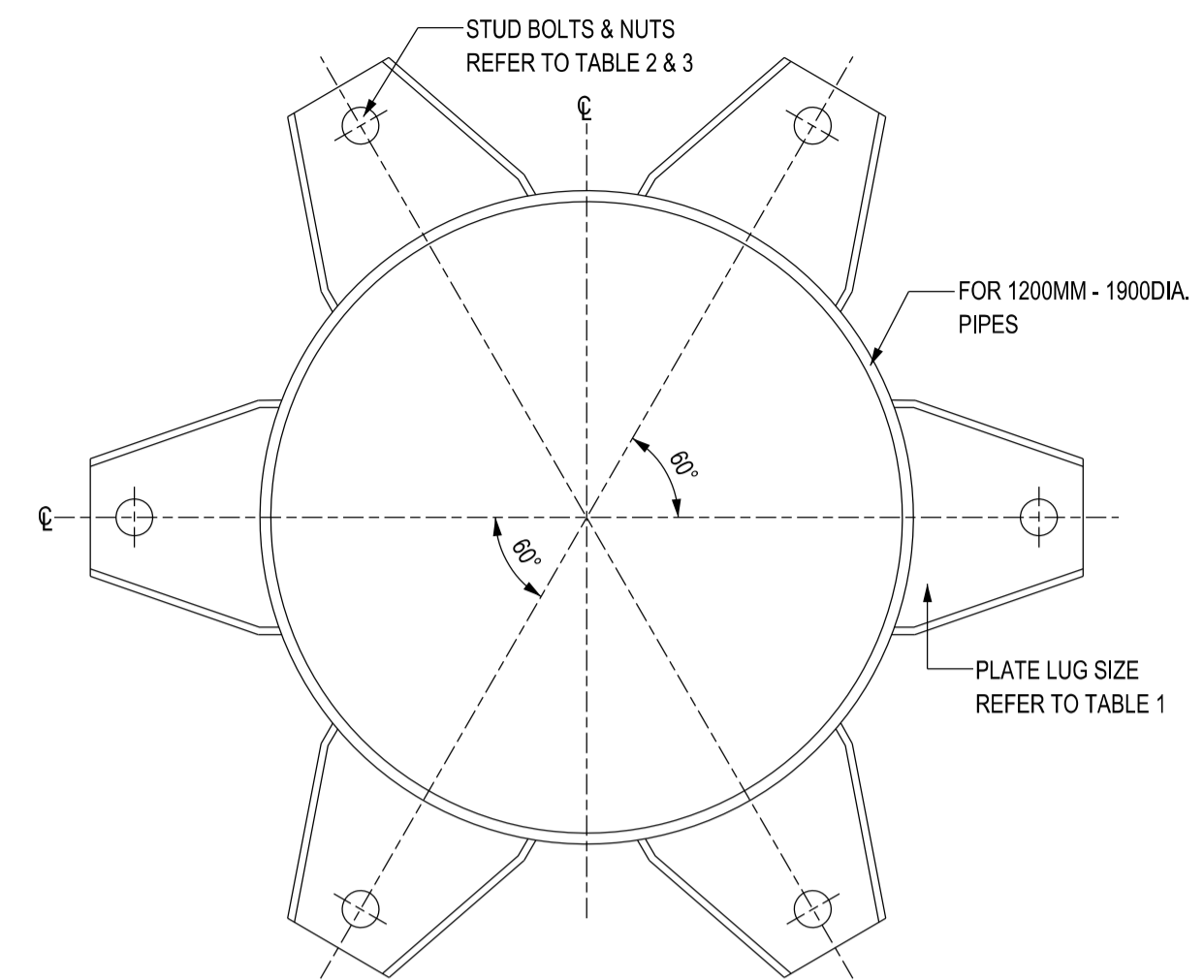

SECTION A-A
FOR 1200MM - 1900MM DIA PIPES
SCALE 1:10

NOTES:

1. ALL DIMENSIONS ARE IN MILLIMETRES UNLESS OTHERWISE STATED.
2. REFER TO THE GENERAL NOTES IN DRAWING NO. PUB/WSN/STD/GN/001.
3. PLATE LUG SHALL BE MANUFACTURED FROM MILD STEEL OF MINIMUM TENSILE STRENGTH OF 235 N/MM².
4. STUD BOLTS AND NUTS SHALL BE MANUFACTURED IN ACCORDANCE WITH B.S. 4882: 1973 AND FROM MILD OR CARBON STEEL OF MINIMUM TENSILE STRENGTH OF 410 N/MM² AND MINIMUM YIELD STRENGTH OF 235 N/MM².
5. STRENGTH OF FILLET WELD SHALL COMPLY WITH B.S. 639.
6. THIS DRAWING SERVES AS ONLY A GUIDE. ACTUAL DIMENSIONS OF PLATE LUG AND STUD BOLTS WILL DEPEND ON THE DIMENSIONS OF RECOMMENDED COUPLINGS.
7. RETAINING RING SHALL BE PROVIDED FOR ALL PLAIN END PIPES TO BE USED WITH MECHANICAL COUPLINGS.
8. INSTALLATION OF JOINT HARNESS SHALL BE APPLICABLE WHERE DUE TO SITE CONSTRAINT.

TABLE 1 - PLATE LUG DIMENSIONS

| PIPE DIAMETER (MM) | PIPE WALL THICKNESS (MM) | PIPE EXT. DIAMETER (MM) | BOLT DIAMETER (MM) | A (MM) | B (MM) | C (MM) | E (MM) | G (MM) | H (MM) | T (MM) | D+3 (MM) | SET PER JOINT (MM) | W (MM) |
|--------------------|--------------------------|-------------------------|--------------------|--------|--------|--------|--------|--------|--------|--------|----------|--------------------|--------|
| 700 | 6.3 | 667.2 | 27 | 200 | 25 | 40 | 95 | 150 | 30 | 8 | 30 | 4 | 6 |
| 800 | 8.0 | 825.9 | 33 | 200 | 25 | 40 | 95 | 150 | 25 | 8 | 36 | 4 | 6 |
| 900 | 9.5 | 933.5 | 39 | 200 | 30 | 45 | 95 | 150 | 25 | 8 | 42 | 4 | 10 |
| 1200 | 12.5 | 1244.7 | 45 | 250 | 30 | 50 | 100 | 150 | 25 | 10 | 48 | 6 | 10 |
| 1400 | 12.5 | 1422.4 | 45 | 275 | 50 | 50 | 115 | 165 | 25 | 10 | 48 | 6 | 10 |
| 1600 | 12.5 | 1549.4 | 56 | 350 | 50 | 60 | 120 | 178 | 32 | 12.7 | 59 | 6 | 10 |
| 1800 | 12.5 | 1746.3 | 56 | 350 | 50 | 60 | 120 | 178 | 32 | 12.7 | 59 | 6 | 10 |
| 1900 | 15.9 | 1911.3 | 56 | 350 | 50 | 60 | 120 | 178 | 25 | 12.7 | 59 | 6 | 10 |

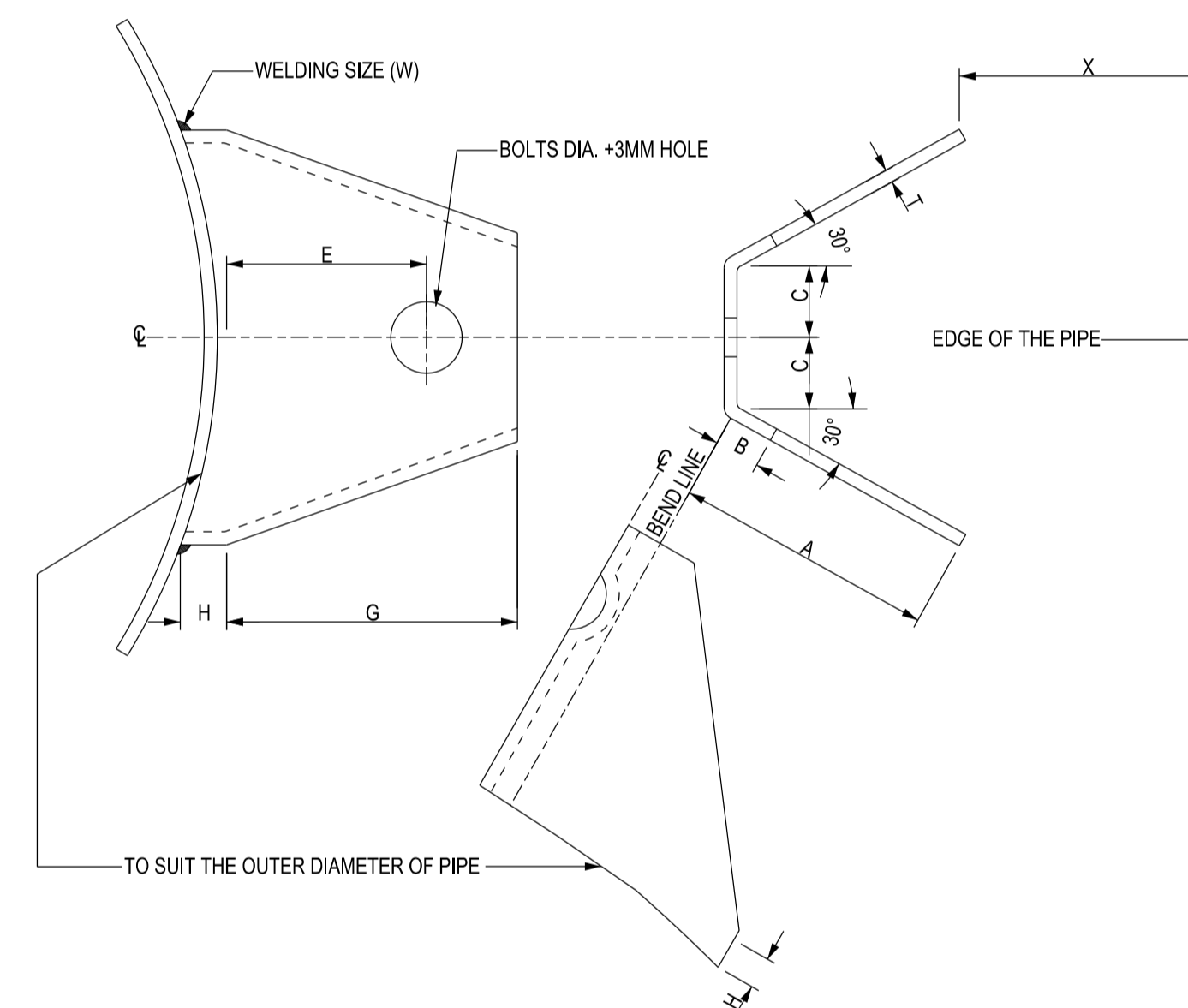

DETAILS OF PLATE LUG
SCALE 1:10

TABLE 2 - STUD BOLT DIMENSIONS

| PIPE DIAMETER (MM) | BOLT DIAMETER (MM) | NUT THICKNESS (MM) | X (MM) | Y (MM) | L ±1.5 (MM) | LENGTH OF THREAD PORTION (MM) | PITCH (MM) | LENGTH OF POINT (MM) |
|--------------------|--------------------|--------------------|--------|--------|-------------|-------------------------------|------------|----------------------|
| 700 | 27 | 22 | 165 | 230 | 910 | 100 | 3 | 3 |
| 800 | 33 | 26 | 170 | 235 | 920 | 100 | 3 | 3 |
| 900 | 39 | 31 | 170 | 235 | 920 | 100 | 3 | 3 |
| 1200 | 45 | 36 | 170 | 240 | 1010 | 100 | 4 | 3 |
| 1400 | 45 | 36 | 175 | 250 | 1070 | 100 | 4 | 3 |
| 1600 | 56 | 45 | 175 | 250 | 1210 | 100 | 4 | 3 |
| 1800 | 56 | 45 | 175 | 250 | 1210 | 100 | 4 | 3 |
| 1900 | 56 | 45 | 180 | 265 | 1230 | 100 | 4 | 3 |

TABLE 3 - HEXAGONAL NUTS DIMENSIONS

| NOMINAL SIZE AND PITCH (MM) | P WIDTH ACROSS FLATS | | Q WIDTH ACROSS CORNERS | | M THICKNESS | | TOLERANCE ON SQUARENESS (MM) |
|-----------------------------|-------------------------|-----------|---------------------------|-----------|----------------|-----------|------------------------------|
| | MAX. (MM) | MIN. (MM) | MAX. (MM) | MIN. (MM) | MAX. (MM) | MIN. (MM) | |
| M27 X 3 | 41.00 | 40.00 | 47.30 | 45.20 | 22 | 21.16 | 0.70 |
| M33 X 3 | 50.00 | 49.00 | 57.70 | 55.37 | 26 | 25.16 | 0.85 |
| M39 X 3 | 60.00 | 58.80 | 69.30 | 66.44 | 31 | 30.00 | 1.03 |
| M45 X 4 | 70.00 | 68.80 | 80.80 | 77.74 | 36 | 35.00 | 1.20 |
| M52 X 4 | 80.00 | 78.80 | 92.40 | 89.04 | 42 | 41.00 | 1.37 |
| M56 X 4 | 85.00 | 83.60 | 98.10 | 94.47 | 45 | 44.00 | 1.46 |

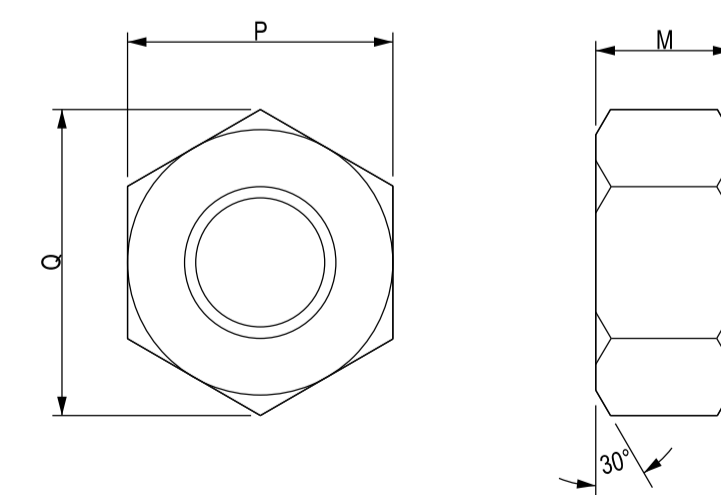

DETAILS OF HEXAGONAL NUTS
SCALE 1:10

ISSUED: NOV 2020

SCALE

DRAWING NO.

LAST REVIEWED: AUG 2021

1:10

PUB/WSN/STD/005

JOINT HARNESS FOR Ø700mm - Ø1900mm PIPE