



8

INNOVATION IN WATER SINGAPORE

An R&D publication of PUB,
Singapore's National Water Agency

June 2016 | Volume 8



Thank you for picking up the latest edition of Innovation in Water | Singapore. We hope you will enjoy reading about some of the latest, cutting-edge water research carried out in Singapore.

PUB, Singapore's National Water Agency, welcomes research collaborations that are in line with our mission: to ensure an efficient, adequate and sustainable supply of water.

Opportunities for collaborative research abound for partners in the water and related industries, universities, and research institutions (local and overseas) who share our objective of securing a safe and sustainable supply of water through use-inspired fundamental research, application and technological development, as well as investment in process improvement, knowledge management and implementation.

R&D online portal SINGwater

To support this endeavour, PUB developed the Singapore INnovation Gateway for Water (SINGwater), an online R&D portal launched in 2013. SINGwater is a platform for interested researchers to learn about PUB's key research initiatives and collaboration opportunities, such as funded programmes for the research, development and test-bedding of technologies at PUB's facilities. SINGwater also serves as a digital pigeonhole for the submission of R&D proposals by external parties, following which approved projects can be managed using SINGwater's built-in tools and functions.

With this portal, PUB hopes to foster closer interaction with its research partners and invite innovative ideas from around the world.

To begin your partnership with PUB, log on to SINGwater at pubwaterresearch.com.sg and create a general user account. For other enquiries, you may contact us at pubwaterresearch.com.sg/ContactUs.aspx.

Contents



Introduction

- 03** Message from the Chief Executive

Editorial

- 04** Investing in technology for water sustainability

Feature

- 06** Industrial water solutions

People in water research

- 09** Mr Jagadish C.V.

Facilities focus

- 10** A field laboratory for testing new water technologies

Research highlights

Intelligent watershed management

- 14** Monitoring reservoir water quality in near real-time
15 Enhanced access to integrated stormwater management system for Marina Barrage
16 Exploring food webs in reservoirs

Membrane technology

- 18** Improving pre-treatment for seawater reverse osmosis
19 Reducing solids retention time in membrane bioreactor systems
20 Using water treatment technology in the oil & gas industry

Network management

- 22** Smart sensors to monitor toxicants
23 Encouraging water conservation with smart water meters
24 Modelling efficient sewer networks using GIS

Used water treatment

- 26** Determining anaerobic biodegradability of enhanced primary sludge
27 Testing advanced used water treatment processes
28 Increasing energy recovery in anaerobic digestion

Water quality and security

- 30** Using the Fish Activity Monitoring System to monitor raw reservoir water
31 Optimising flow cytometry protocols to monitor water quality
32 Hyperspectral monitoring of surface water bodies in real time

Water treatment

- 34** Reducing algae in freshwater feeds at waterworks
35 Using electrodialysis for low-energy municipal desalination
36 Optimising biologically activated carbon filters

PUB collaborators

© 2016 PUB, Singapore's National Water Agency

All rights reserved. No part of this publication may be reproduced, stored in a retrieval system or transmitted in any form or by any means, electronic, mechanical, photocopying, recording, or otherwise, without the prior written permission of PUB, Singapore's National Water Agency.

PUB, Singapore's National Water Agency

40 Scotts Road, #22-01
Environment Building
Singapore 228231
www.pub.gov.sg

Paving the way for water innovation



Water is both a key strategic and economic asset in Singapore. With water technology as a key pillar of economic growth, PUB, Singapore's National Water Agency and the Economic Development Board work closely with other government agencies, companies and research institutes to develop Singapore into a thriving global hydrohub. Steered by a clear focus on innovation, we offer a range of support to companies that comprises research funding, graduate scholarships and test-bed opportunities for cutting-edge solutions.

Let us help bring your innovations to fruition.



Message from the Chief Executive



There can only be more demand for water in Singapore as industry and commerce grow and the population increases. Current consumption is about 430 mgd, 55 per cent of which is non-domestic, used up by factories and businesses. Total demand should double by 2061, when our remaining water agreement with Malaysia ends.

Singaporean water consumption rates, although already low by international standards, is still wasteful. The perennial challenge remains how to engender even more frugal and judicious usage without sacrificing modern-day convenience and facility.

Much of the water expended by industry is used for cooling and processing. A lot of it is used only once and then either lost to the atmosphere or discarded. This is unnecessarily profligate, unsustainable and will have to be continually curtailed.

The 100 odd facilities on Jurong Island alone use up 46 million gallons of water a day. That is almost 10% of Singapore's total daily demand! Water conservation and efficiency, recycling, localized reuse and seawater substitution are some of the things that our industries have to look seriously at, and then adopt in a big way. In this eighth edition of *Innovation in Water Singapore*, we put the spotlight firmly on optimizing industrial water use.

PUB drives water research in Singapore with three aims in mind. We seek to (a) increase water resources, (b) reduce cost of production and (c) improve quality and security. At the time of publication, the R&D project count stands at 467, with a collective value of \$323 million.

Unknown to many, PUB operates a significant water research facility in Tuas, right next to Tuaspring Desalination Plant. This location offers invaluable opportunities for test-bedding and for deploying pilot-scale demonstrations under field conditions. In this issue, learn more about what BASF, GE Water, PWN and others are up to at our joint in Tuas.

Last but certainly not least, we are pleased to profile Jagadish CV and the organization that he leads, the Systems on Silicon Manufacturing Company. SSMC was the first wafer fabricator in Singapore to use NEWater, way back in 2002. And Jagadish, its current CEO, is a tireless champion of water conservation and reuse.

The biennial *Singapore International Water Week* is almost upon us. SIWW 2016 takes place 10 to 14 July at the Marina Bay Sands and will again gather together, for dialogue and discussion, the world's top leaders in the water sector, from government, utilities, international organisations, industry and academia. SIWW offers an unprecedented networking opportunity to interact and confer with high officials, heads of industry and opinion makers. You can also expect to rub shoulders and exchange viewpoints with mayors of leading international cities who are attending the *World Cities Summit* and *CleanEnviro Summit Singapore*, both held alongside SIWW 2016. You don't want to miss it!

NG JOO HEE

Chief Executive

PUB, Singapore's National Water Agency

Investing in technology for water sustainability

Singapore's unique water environment requires innovative solutions, and research and development (R&D) has been the key to achieving a robust, affordable and sustainable water supply. With water demand expected to more than double by 2060, continual investment in R&D to seek more cost-effective and efficient ways of treating, recycling and supplying water is vital, especially in light of challenges such as climate change, rising energy costs, population growth and increasing urbanisation.

Innovation for water sustainability

As Singapore's national water agency, PUB manages the water loop, from the management of our reservoirs, collection of rain, treatment and supply of water to the population and industries, to the collection and recycling of used water.

The country uses on average 430 million gallons a day (MGD) of water. With demand expected to more than double by 2060, collecting every drop of water, reusing water endlessly, and desalinating more seawater – principles that guide PUB in its integrated water management – are crucial. Continual investment in water technology R&D is key to achieving that.

Since PUB was established in 1963, it has faced challenges in ensuring a secure, safe and adequate supply of water. At that time, a lack of natural resources, pollution and a rapidly changing urban environment, were among the various factors that led the country to invest in developing its R&D capabilities to build a diversified and sustainable water supply.

Singapore began looking into unconventional water sources as far back as the 1970s, but membrane technology was costly and unreliable at that time. It was only in the 1990s that the cost and performance of membrane technology improved considerably, and PUB revisited the idea of water reuse. After extensive R&D, including the commissioning of a full-scale demonstration plant, a three-stage membrane-based production process was developed, and NEWater was introduced in 2003. Treated used water is put through microfiltration, reverse osmosis and ultraviolet disinfection, to produce high-grade, ultra-clean reclaimed water. Today, Singapore has four NEWater factories that can meet up to 30% of its water needs, and by 2060, NEWater will be able to supply up to 55% of the country's water demand.

Following the success of NEWater, PUB introduced desalinated water in 2005 with the opening of the SingSpring Desalination Plant. Singapore's second desalination plant, Tuaspring, commenced operations in 2013, and plans are in place for two more plants to be built by 2020 to boost the country's drought resilience. Desalination will meet up to 30% of Singapore's future needs by 2060.

Alongside these initiatives that diversified Singapore's water sources and made supply more robust, PUB also aims to augment existing water resources by making every drop of rain count. Two-thirds of Singapore is water catchment, and the plan is to increase Singapore's water catchment area to 90% in the long run.

Driving advancements in water R&D

R&D has helped Singapore achieve an adequate and secure water supply, and it continues to be vital in ensuring a sustainable water supply for the future. Water research is carried out with three objectives: (a) increase water resources, (b) reduce cost of production, and (c) improve quality and security.

Launched in 2004, PUB's R&D programme supports local and global research institutions, water companies and utilities in developing innovation water solutions to meet these objectives.

It develops potential solutions in six technology groups – Intelligent Watershed Management, Membrane Technology, Network Management, Used Water Treatment, Water Treatment, and Water Quality and Security. The total number of projects the agency is involved in currently stands at 467, with a collective value of S\$323 million, and continues to grow.

These projects are aligned strategically to achieve the three research objectives, and are detailed in a R&D roadmap that directs research efforts and connects new



ideas to these larger, long-term goals. The roadmap currently covers seven key water domains spanning the entire water loop: biological processes; chemical redox technologies; desalination and water reuse; sludge and brine management; automation and robotics; watershed management; water quality analytics and water distribution.

Reflecting PUB's relentless drive for new and innovative solutions, three new focus areas were also recently added to the R&D roadmap, namely: groundwater and underground caverns for water storage and water facilities, decentralised water treatment technologies to optimise land use, and industrial water technologies to meet the challenges of industrial water management.

Building a global hydrohub

Beyond managing the water loop in Singapore, PUB plays a key role in nurturing the development of the local water industry, which has become a global hub for some of the most advanced and innovative water research across the entire water value chain. The complexity of water issues often requires close collaboration with partners both locally and globally - including governments, international organisations, research institutions and industry players - to foster strong and mutually beneficial networks.

It is in this spirit of sharing that the Singapore International Water Week, a biennial water conference which facilitates dialogue and learning among policymakers, water experts and industry leaders on global water issues, challenges and solutions, was conceived. PUB also facilitates sharing of experiences through hosting visits to its facilities, organising workshops for training and knowledge exchange, and collaborating with like minded water utilities and organisations on R&D.

To this end, PUB has signed memorandums of understanding with various partners over the years,

including agreements with Korea Water Resources Corporation on the collaboration in smart water grids, water quality monitoring, green energy and water treatment processes; Asia-Europe Meeting (ASEM) Water Resources Research and Development Centre on knowledge exchange and sharing of best practices in water quality management and energy recovery; VCS Denmark to accelerate the sharing and creation of solutions, specifically in the areas of used water technology and operations, energy reduction and climate adaptation; and SUEZ on three projects in used water treatment, stormwater management and automated meter reading.

PUB, together with related partner agencies, also facilitates product development and offers financial incentives to encourage the early adoption of new technology by end-users. Private sector companies can test their new technologies on-site at PUB's various facilities, comprising water treatment plants, water reclamation plants, NEWater factories, used water and water supply networks, reservoirs and waterways, all under actual operating conditions, a key step for the eventual application and commercialisation of these technologies. Stakeholders are also given financial and technical support for their activities.

Today, 180 local and international water companies, alongside more than 20 research institutes, create a dynamic water landscape in Singapore. In all, around 14,000 jobs have been added, and close to S\$2.2 billion in value add have been created for the local economy in the past 10 years.

Thus far, Singapore's technology-forward philosophy and investments in R&D have enabled the country to develop a world-class, innovation-driven water industry. As PUB continues to invest in innovation and use science and technology to address its challenges, it will be able to turn what seems impossible into endless opportunity.

Industrial water solutions

Jurong Island is home to more than 100 petroleum, petrochemical, specialty chemical and supporting companies. About a tenth of Singapore's water demand now comes from there, almost all of which is met by PUB supplying various grades of water. To meet projected future demand, PUB is supporting new ideas and technologies in the area of Industrial Water Solutions (IWS).

The landscape of IWS in Singapore

By 2060, homes will make up just 30% of Singapore's water demand, with the non-domestic sector, which includes industries, using the rest. Managing industrial use of water is thus a priority, especially as Singapore also hosts water-intensive businesses such as petrochemicals, electronics and pharmaceuticals.

Globally, the industrial sector is the second-largest consumer of water behind agriculture. Its efforts towards water sustainability are crucial - in particular, implementing effective water and used water treatment technologies, as well as being open to innovative technical solutions and strategies can increase the efficient use or reuse of water in industrial processes. For example, reducing evaporative losses through alternative cooling methods and recycling treated effluent are two potential areas where innovative industrial water solutions can be applied to reduce water use. Other potential areas for innovation include tapping waste heat for energy-saving seawater desalting technologies, as well as using alternative sources of water (i.e. seawater) for cooling.

To ensure that future demand for water can be met, PUB has been encouraging the industrial sector to look for innovative solutions to reduce costs and improve water sustainability and management. Economically, Singapore's IWS sector is also fast-growing (at about 10% a year) and presents business opportunities for water companies here in supplying ultra-clean water, or water treatment solutions.

Water use on Jurong Island

Industries on Jurong Island contribute to about 10% of Singapore's daily water demand. A small fraction of Jurong Island's water demand is also met by privately owned desalination plants on Jurong Island. Most of the water used by these industries is lost to evaporation or discharged to the sea as treated effluent.

It is estimated that about 40% of water demand on Jurong Island is used in cooling towers that transfer process waste heat to the atmosphere through evaporation. Of this, about half of it cannot be recovered.

Seawater cooling, which involves removing unwanted process waste heat with seawater through a difference in temperature between two heat exchangers, can be used as an alternative water source for these cooling towers. Although these systems use substantially more water as the water is not recirculated, seawater cooling reduces energy consumption considerably as the seawater only needs to be screened before use, compared to the more energy-intensive water reclamation process that is necessary to produce NEWater. With industries located close to the sea, less energy is also required to use seawater as the cooling medium, in contrast to NEWater which has to be piped in.

Efforts to encourage water sustainability on Jurong Island

To ensure that water demand on Jurong Island continues to be met even as industry water use increases, PUB supports the development of innovative water technologies from its infancy to commercialisation. Novel, promising technologies are funded in a coordinated manner so that there is holistic development in both the technical and commercialisation aspects of technology implementation.

PUB has been soliciting new ideas and technologies in the domain of IWS, with the aim of improving water management to achieve water sustainability. Projects supported by PUB focus on the development and demonstration of innovative technologies, approaches and ideas capable of reducing water consumption (potable water, NEWater and/or industrial water) in industries.



© JTC

Ongoing IWS projects in Singapore

Today, there are several ongoing IWS projects in Singapore that are aimed at developing and demonstrating technologies that can help reduce water consumption for industries.

Mitsubishi Heavy Industries-Asia Pacific (MHI-AP) is exploring the use of seawater for cooling, to take advantage of the abundance of seawater surrounding Jurong Island. This can potentially reduce the company's consumption of NEWater, which can be diverted for other uses.

Seawater cooling can be adopted in a once-through process, or in an evaporative cooling system such as a cooling tower. The latter is more environmentally-friendly, particularly when adopted in a network system in industrial areas. MHI-AP's cooling tower solution integrates a water intake structure, eliminating the need for a large intake chamber in an already land-constrained area. The company cited the potential to extend seawater cooling to other end users to reduce NEWater demand

and eliminate outage risks if overall operation costs can be optimised, as well as the possibility of implementing similar projects in different sectors on Jurong Island, or in other industrial estates abroad (Fig. 1).

A private refinery on Jurong Island plans to treat effluent water from its existing used water treatment plant at a water recycling plant currently under construction (Fig. 2), and reuse the treated water in its refinery. The plant will be able to treat 2,000–2,500 cubic metres of water daily using flat sheet ceramic membranes and a two-stage reverse osmosis process to remove suspended solids, oil, grease and other contaminants from the treated used water (Fig. 3). This facility would reduce the company's NEWater consumption by 2,000 cubic metres a day and increase its water recycling rate from the current 18% to 41%.

Wafer fabrication company GlobalFoundries is also hoping to reduce its NEWater consumption by 10% through water saving, water recovery and reuse measures. The manufacture of semiconductor integrated circuits



© Mitsubishi Heavy Industries-Asia Pacific

Fig. 1: MHI-AP's seawater cooling tower system, currently in operation in Indonesia



© Meiden Singapore Pte Ltd

Fig. 2: A 3-dimensional model of the refinery's effluent treatment plant

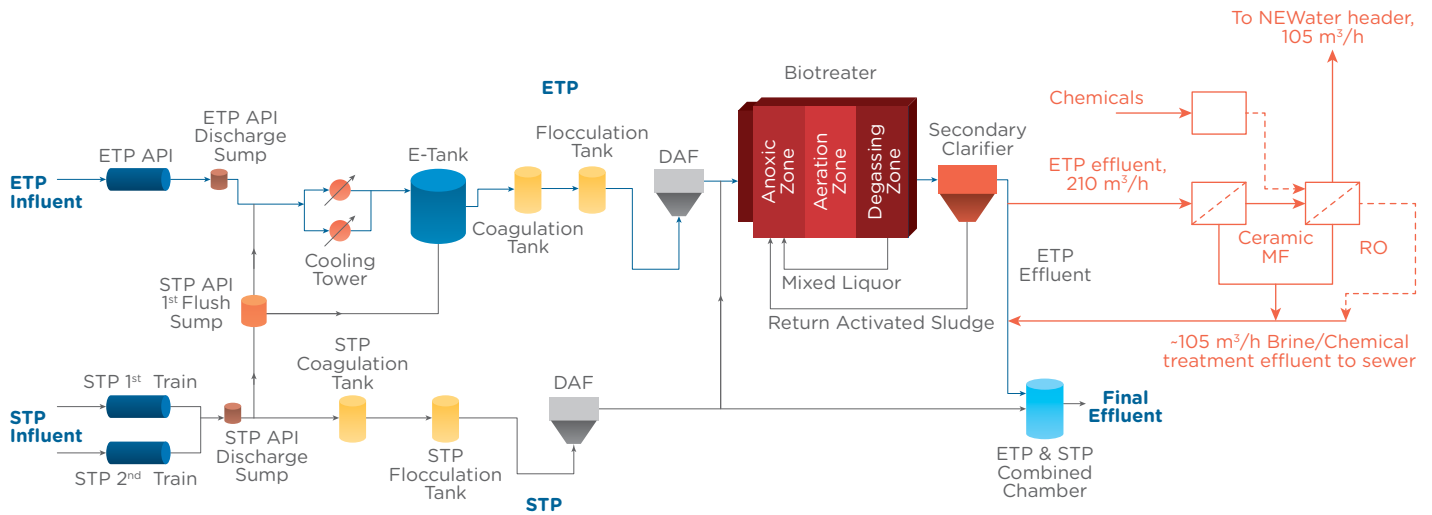

Fig. 3: Process flow of the refinery's effluent treatment plant



Fig. 4: GlobalFoundries' pilot-scale treatment system for its used water stream



Fig. 5: Pilot-scale ion exchange system used by GlobalFoundries

involves multiple steps and complex sequences that require large amounts of ultra-clean water, and a solution to recover water from semiconductor used water streams would result in cost savings for the company.

The company is currently working with the Nanyang Environmental and Water Research Institute (Nanyang Technological University) and PUB to develop a pilot water recycling plant that uses a multimedia filter, activated carbon filter, and reverse osmosis to remove total organic carbon, suspended solids, ions and other impurities from the used water stream (Fig. 4), and a more cost-effective ion exchange system for another stream of water with low total dissolved solids (Fig. 5). Going forward, the team will focus its efforts in a full-scale water reclamation system that will be constructed based on the optimised process configuration and test results gathered.

By understanding the water needs of the various industries, we can thus promote innovative technologies and water audits to make their facilities and manufacturing processes more water-efficient. This would contribute to achieving long-term water sustainability and grow Singapore's thought leadership in this field globally, contributing to its position as a leading global hydrohub.

© GlobalFoundries, Nanyang Technological University

© GlobalFoundries, Nanyang Technological University

People in water research

Mr Jagadish C.V. CEO of Systems on Silicon Manufacturing Company (SSMC)

Mr Jagadish C.V. was appointed CEO of Systems on Silicon Manufacturing Company (SSMC), a joint venture between the Taiwan Semiconductor Manufacturing Company and NXP Semiconductors, in December 2006. He graduated with a first class honours bachelor's degree in Electronics & Communication from the National Institute of Engineering Mysore, India, and completed the International Executive Program by INSEAD Management School, France. He has worked extensively in business development and the semiconductor industry, and is a member of the NXP Semiconductors operations management team. Mr Jagadish has been the Deputy Chairman of the Singapore National Quality Award Governing Council and Power Quality Advisory Panel since 2007. He has also been the Vice Chairman of Semiconductor Equipment and Materials International, Singapore Regional Advisory Board since 2010; and Deputy Chairman of the PUB Water Network since 2015.

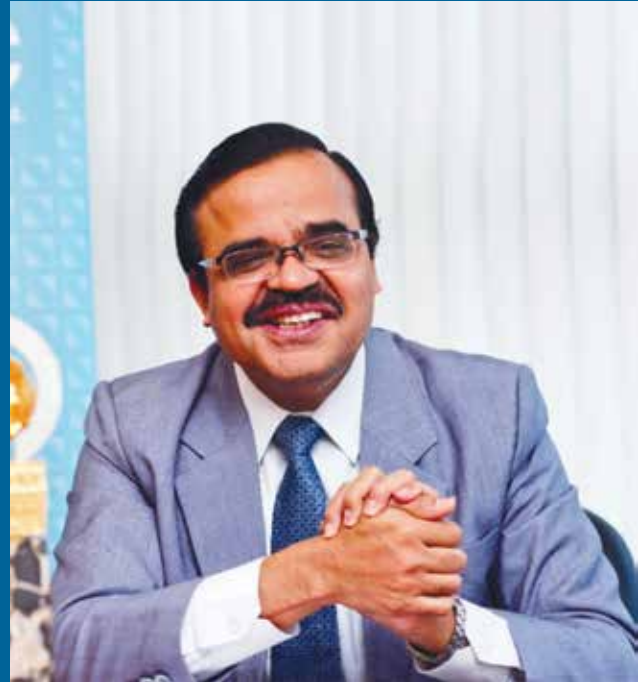

© Systems on Silicon Manufacturing Company

Water resilience for competitiveness

I distinctly remember walking to the river in my village to fetch drinking water and drawing from the well in the early stages of my life. These humbling experiences have deeply ingrained in me a strong appreciation for our world's natural resources and a bigger perspective of water which is our national asset today.

As with all companies in the semiconductor wafer fabrication industry, having a consistent supply of good quality water is of vital importance to SSMC's manufacturing process. Even a slight contaminant at a part per billion level could penetrate through the purification process and be harmful to the delicate micro devices. Today, SSMC's manufacturing processes require a daily water usage equivalent to 6,500 4-room Housing Development Board flats, and up to 130,000 cubic metres of consistently good quality water per month.

In 2002, SSMC became the first company to use NEWater for wafer manufacturing when it was introduced as a source of water supply in Singapore. It was a bold step towards water sustainability and conservation, and one that has paid off for us. As a supply of high-grade, ultra-clean water, we have found NEWater to be of better quality for industrial use. It also removed our need to further treat tap water to meet wafer fabrication standards, thus saving on maintenance costs. There has been no trade-off involved and we were able to achieve a healthy and meaningful return on investment within a few years.

Environmental conservation as a corporate social responsibility

SSMC is committed to the conservation of our environment. This is a corporate social responsibility, and

I believe that efforts have to start at the top, which then cascade down to other levels in the organisation.

My belief is that switching to NEWater alone is not enough, and we need to look at ways to further reduce our water consumption. Our water recycling facility currently recycles NEWater 3.5 to 4 times before it is discharged, and we hope to increase this rate to 6 times. Other water conservation initiatives include reusing used water, optimising flow rates, and commissioning a new plant to recycle used water.

SSMC also believes strongly that environmental awareness starts from young, and has adopted three schools to promote environmental consciousness among youths. In addition, SSMC has adopted Lorong Halus Wetland since 2012 and conducts Active, Beautiful, Clean (ABC) Waters Learning Trails to share information about the area with the public.

Industrial water sustainability

With our efforts, SSMC's water consumption per wafer produced has fallen over the years, while our water reclamation rate has grown from 50% to 80% between 2011 and 2015. This has yielded an annual reduction of about 1 million cubic metres of water since 2003. SSMC remains committed to exploring new technologies for reclaiming water and its by-products like fluoride, and new methods of water treatment before discharge. We also hope to further our collaboration with PUB and explore more ways to conserve water in our operations.

A field laboratory for testing new water technologies

Desalinated water is one of Singapore's Four National Taps, along with local catchments, imported water and high-grade reclaimed water (also known as NEWater). Like NEWater, desalinated water is not dependent on rainfall, and boosts Singapore's resilience against dry weather, helping to strengthen its water security.

The country's first desalination plant, SingSpring, was opened in 2005 with a capacity of 30 million gallons per day (MGD). The first water project to be awarded under the public-private partnership (PPP), SingSpring was appointed to design, build, own and operate the plant, and supply desalinated water to PUB for a period of 20 years.

A second larger desalination plant, Tuaspring, commenced operations in 2013 under a similar PPP arrangement, adding an additional 70 MGD of desalinated water to Singapore's water supply. Preparation for the construction of two more desalination plants at Tuas and Marina East have commenced, and PUB is also exploring the potential of building a fifth plant on Jurong Island. This is in line with plans to grow Singapore's desalination capacity, so that this Fourth National Tap will be able to meet up to 30% of water demand by 2060.

Of the Four National Taps, desalination is the most energy-intensive. Current desalination practices in the industry tend to rely on reverse osmosis (RO) technologies to remove salt from the water, with energy consumption of seawater RO (SWRO) processes constituting a significant portion of a desalination plant's total operating costs. The piloting and test-bedding of desalination-related technologies to reduce the energy consumption is thus crucial in developing desalination as a more energy-efficient and environmentally-sustainable process.



Fig. 1: Different types of feed water received from Tuaspring desalination plant



An essential investment

Currently, the desalination plants in Singapore are operated by partners from the private sectors. In order to facilitate the test-bedding and R&D of desalination-related technologies, PUB commissioned an R&D facility in Tuas in 2013, where desalination-related technologies, among other technologies, can be tested. Located next to the Tuaspring desalination plant, the facility receives three types of feed water, namely: seawater, ultrafiltration (UF) filtrate and SWRO brine from Tuaspring (Fig. 1). It provides a location for PUB and its research partners to conduct a range of pilot and demonstration-scale studies in actual field conditions. Partners who are currently testing related technologies ranging from pre-treatment to membrane and desalination technologies include institutes of higher learning, such as the Nanyang Technological University of Singapore, as well as private players such as Hitachi, GE Water & Process Technologies and PWN Technologies.

Validating laboratory findings in the field

One such company is BASF subsidiary inge GmbH (Germany), which is using the facility for a demonstration study of a novel UF membrane (Fig. 2). Made of a material that exhibits superior anti-fouling properties, the membrane can thus be operated at a higher flux, lowering capital expenditure and operational costs for water treatment.

The performance of these new membranes was first evaluated in a laboratory, where they successfully exhibited a decreased fouling propensity. To further validate these findings, the membranes were then tested in a pilot plant at the R&D facility under similar conditions as actual UF operations during the pre-treatment process for SWRO.

“PUB’s Tuas R&D facility is excellent as it is able to offer us a continuous feed water supply in actual field conditions for our study. This has enabled us to quickly and consistently assess our UF membranes, which are



Fig. 2: BASF testing its new membrane

© BASF SE, inge GmbH



© GE Water and Process Technologies

Fig. 3: GE’s RED/dRED pilot system

freshly manufactured in our laboratories in Ludwigshafen and Singapore,” research scientist Natalia Widjojo from the BASF Global Research Center said.

Aiding process optimisation

Another research project being carried out at the R&D facility is by GE Water & Process Technologies on reverse electrodialysis (RED)-based seawater desalination technology. The company aims to demonstrate the use of RED and driven reverse electrodialysis (dRED) processes in increasing water recovery rates of existing desalination systems using low salinity effluent from used water reclamation processes as a salt sink (Fig. 3).

Over the past year, the company’s research team has focused on developing and studying the various aspects of the hybrid SWRO-RED/dRED process, including ion-exchange membranes, flow path enabling spacers and a techno-economic model to evaluate the practical feasibility and scale-up potential of the technology.

“Preliminary pilot results on the RED/dRED process have been encouraging. The hybrid process, in comparison with conventional SWRO process, shows the potential for near-100% system recovery, about 10% reduction in the cost of water and about 14% reduction in energy consumption,” GE’s Harikrishnan Ramanan said. He pointed out that it is an environmentally-friendly process with benefits of reduced outfall discharge and lower seawater desalination costs.

Ramanan said that this year, his team hopes to conduct a multiple-stage pilot (Phase II) at the facility that will focus on scaling and fouling during its long-term continuous operation.

Validating technology in different applications

The benefit of conducting tests at the R&D facility is that it reduces the risk of technology implementation by allowing companies to test their technologies out on a pilot scale operation. PWN Technologies, working with Wabag and

Metawater, used the facility to test the effectiveness of its ceramic membranes, previously tested and validated in drinking water application, as a pre-treatment process for SWRO over a four-month period (Fig. 4).

The trial focused on operational optimisation, specifically, filtration run-time, and backwash and chemical cleaning procedures and frequencies to maximise the efficiency and recovery of the pilot plant. The company’s pilot plant at the facility had a capacity of 200 cubic metres a day and used a single ceramic membrane of 25 square metres filtration area with a nominal pore size of 0.1 microns.

Principal investigator Gareth Milton said the supply of partially treated (chlorinated) seawater to the pilot plant at the R&D facility eliminated the need for any abstraction or pre-treatment, simplifying its operation.

“Piloting can be performed on seawater or from an operational abstraction point, thereby providing representative seawater for testing. This allows the membrane’s performance to be monitored and optimised based on changing raw water quality that would be observed for pre-treatment on a full-scale system, both daily and seasonally,” Milton said about the facility.

PUB’s efforts to encourage the early adoption of novel water technologies by providing a valuable opportunity for technology developers to perform trials under actual operating conditions allow the agency to fast-track the introduction of novel, proven technologies to the marketplace. The agency’s commitment to providing a conducive environment for technology developers to test new ideas and technologies at its facilities further enhances Singapore’s position as a global test bed and living laboratory for water R&D.



© PWN Technologies

Fig. 4: PWN Technologies’ pilot plant

For more information on R&D and test-bedding opportunities at PUB facilities, please visit PUB’s online portal for R&D, SINGwater, at <https://pubwaterresearch.com.sg>.



INTELLIGENT WATERSHED MANAGEMENT

The Intelligent Watershed Management programme aims to leverage developments in instrumentation, controls and innovative information technology solutions as modeling tools for hydraulics and hydrology research. These enhance Singapore's capability in managing its water resources. Using high-level simulations, water researchers in Singapore can forecast future events and plan efficient countermeasures.

Monitoring reservoir water quality in near real-time

Exploring the use of hyperspectral imaging technology on land to monitor reservoir water quality

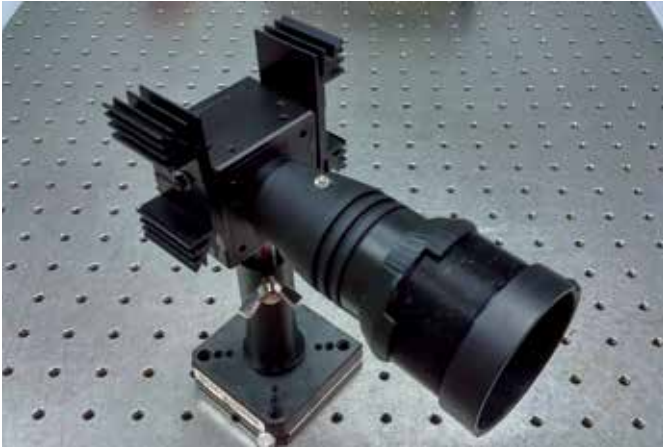

Fig. 1: HSI sensor prototype used for remote sensing of water quality

© Lighthaus Integral Pte Ltd



Fig. 2: Testing and calibrating the HSI sensor at Serangoon Reservoir

© Lighthaus Integral Pte Ltd

Hyperspectral imaging (HSI) technology collects and processes information from across the electromagnetic spectrum of each image pixel to find objects, identify materials or detect processes. The technology has been used in defence and large-area satellite remote-sensing applications such as forestry studies, environment measurements and mineral detection. However, satellite-based HSI technology has not been used to monitor water quality because it is limited by unpredictable weather and cloud cover, low spatial resolution (exceeding 30 square metres), long sampling intervals ranging from days up to weeks, and high operational costs.

To overcome these limitations, a team from Lighthaus Integral, supported by PUB, is exploring the use of “Earth-based” HSI technology to monitor water quality at Singapore’s reservoirs in near real-time. Unlike its satellite counterpart, Earth-based HSI is not affected by cloud cover and is both versatile in deployment and economical for long-term and continuous use.

“An advantage of Earth-based HSI technology over existing on-site monitoring methods is that it is able to directly map two-dimensional images of the target area, with every pixel containing its spectral information,” Lighthaus Integral’s Choo Chun Keong said.

Lighthaus Integral’s customised HSI sensor (Fig. 1) is suitable for water quality monitoring, as it is able to capture more than 30 bands per pixel, providing a richer and more detailed picture. While HSI sensors are largely suited for laboratory use, the sensor that is currently being explored is weather-resistant, and thus suitable for outdoor use. It is also cost-effective for long-term deployment, allowing changes in water quality indicators to be monitored over an extended period of time.

The system’s detection algorithm was also customised for Earth-based deployment and to monitor reservoir water quality indicators, including chlorophyll-a, turbidity and flotsams like surface litter. The algorithm,

based on the water-leaving reflectance principle, was developed together with specialists from the Centre for Remote Imaging, Sensing and Processing (CRISP) at the National University of Singapore using water quality data from laboratory samples and measurements taken at local reservoirs.

Site tests of the water-leaving reflectance measured at Punggol and Serangoon reservoirs showed a high degree of correlation between both laboratory samples and data captured by a reputable hand-held single point spectrometer (Fig. 2). HSI sensors are currently being deployed on tall structures and buildings near the reservoir to monitor the surface water quality of the entire area. According to Choo, the detection algorithm will be further developed and verified using more data collected on-site. He added that more research into Earth-based HSI could lead to novel, cost-effective and efficient area monitoring and better surface water quality mapping at reservoirs as its spatial resolution can reach one square metre.

Researchers and affiliations

C.K. Choo | *Lighthaus Integral Pte Ltd*

T.C. Dang | *PUB Singapore*

Contact

C.K. Choo; keong@lighthaus.com.sg

Enhanced access to integrated stormwater management system for Marina Barrage

New customised dashboard promises streamlined access to real-time data for better decision support

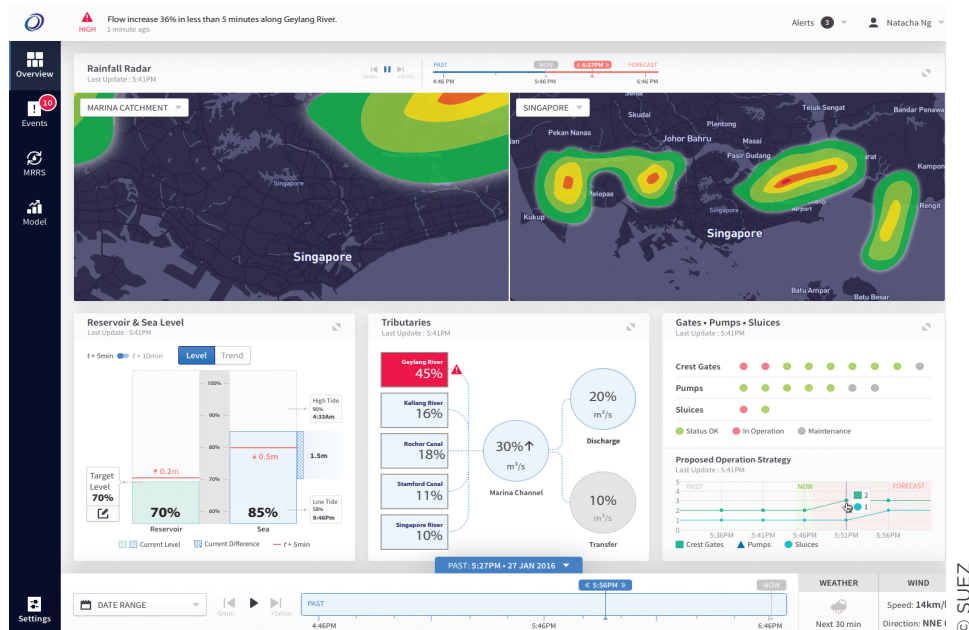

Fig. 1: Marina Barrage's Integrated Stormwater Management System (figures do not represent actual values)

The Marina Barrage dams up the mouth of the Marina Channel, creating Singapore's first reservoir in the heart of the city, the Marina Reservoir. The Marina catchment is Singapore's largest and most urbanised catchment, with five main rivers feeding into the Marina Reservoir, providing a source of water supply. In addition, the barrage also acts as a tidal barrier, helping to alleviate floods in low-lying city areas.

Managing the water level in the reservoir is important to maximise storage while minimising flooding risks upstream during storms. At low tide, the dam's crest gates can be opened to release excess water into the sea during heavy rain, while during high tide, the gates remain closed and seven pumps help to flush out water. These tasks, along with water recirculation to improve water quality in the reservoir, are carried out with the help of an operational management system (OMS) that integrates different data sources and water quality parameters.

The OMS is a real-time modelling platform designed to compute short-term rainfall forecasts, estimate the ensuing water flow in the catchment and to propose operational strategies to Marina Barrage operators to deal with the excess water coming into the reservoir during storms. PUB brought French waste and environmental services company SUEZ on board in mid-2015 to contribute to the development of the OMS, building on the large network of sensors and advanced models the agency has already developed for it.

The upgrading of the OMS involves streamlining access to real-time data on rainfall, water levels in drains and

canals as well as in reservoirs, and water flow in the catchment through an integrated interface (Fig. 1). Such integrated access to various data can aid and facilitate ground decisions on the operational measures to take during a storm. SUEZ will also tailor its user interface with the input of Marina Barrage operators and PUB's Drainage Operations and Water Quality Management and Modelling divisions.

"The new dashboard will be practical, as we are improving on the user interface by focusing on the needs of operators managing the reservoirs and its upstream tributaries," SUEZ project manager Olivier Pison said about the system upgrades.

He added that the dashboard will be able to provide advanced water quality monitoring, integrating different data sources on water quality indicators like algal blooms, pollution and fish kills. The upgraded dashboard will be fully operational in late-2017.

This research is co-funded by PUB and the Singapore National Research Foundation under its Technology Pioneer (TechPioneer) grant. The grant is administered by PUB and the Singapore Economic Development Board (EDB).

Researchers and affiliations

O. Pison | SUEZ

A. Mahadevan | PUB Singapore

Contact

O. Pison; olivier.pison@suez.com

Exploring food webs in reservoirs

Establishing biodiversity profiles of Singapore's reservoirs for better ecological management



Fig. 1: Researchers conducting electrofishing to sample fishes in the reservoir

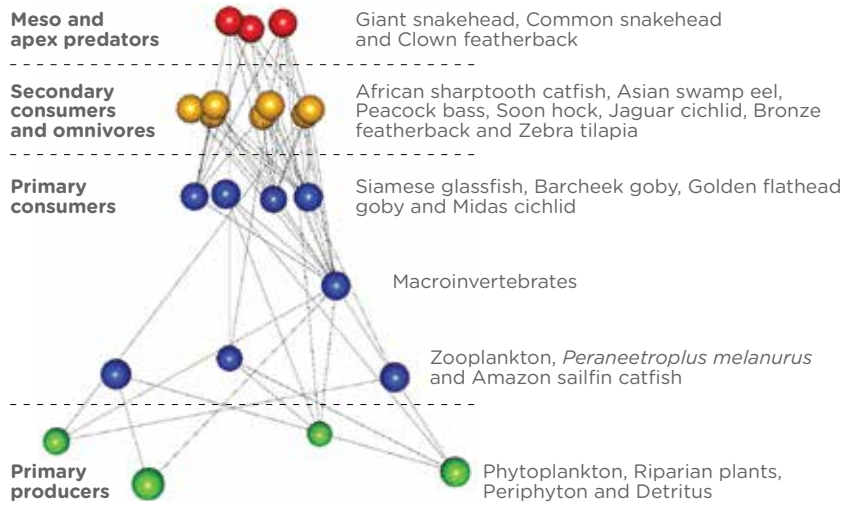

Fig. 2: Three-dimensional hypothetical food web of the aquatic community in one of the reservoirs surveyed

Singapore's freshwater reservoirs are not only sources of water supply, but also ecosystems where different organisms thrive. In general, one of the indicators of a reservoir's health is the vibrancy of its biodiversity. This is one of the main drivers behind a 30-month pilot study led by Darren Yeo Chong Jinn of NUS, in partnership with PUB and in collaboration with Tim Jardine of the University of Saskatchewan, Canada. The study aims to develop a comprehensive profile of the aquatic biodiversity of six of Singapore's freshwater reservoirs. With the insights gained on the diversity and richness of aquatic plants and organisms, as well as their biological interactions, the team aims to assess the potential of biological ways to improve the ecology and water quality (biomanipulation), which can then be harnessed to further develop targeted measures as part of holistic reservoir management.

The profiles of fishes in the reservoirs, as well as other major aquatic organismal groups including benthic macroinvertebrates, zooplankton, phytoplankton, and plants, were investigated in the study. A variety of established sampling methods were adopted, including seine netting, cast netting, angling, long lines and electrofishing. Electrofishing is a common scientific survey method used internationally to sample fish populations to determine biological and ecological aspects of fish communities. In this project, fishes were temporarily immobilised using electricity without causing them permanent damage (Fig. 1). The fishes were then weighed and tagged before being released back alive into the water.

Determining the food webs is the next stage of the study. Stable isotope analysis (SIA), which measures naturally-occurring isotopes of carbon and nitrogen in plant or animal tissue, was used. Similarities in isotopic compositions indicate similar food sources and trophic levels. Together with gut content analysis via DNA barcoding, SIA helps to determine predator-prey

interactions and the relative positions of organisms within a food web (Fig. 2).

Lastly, small-scale experiments, where cages of varying mesh sizes were used to selectively exclude fishes based on size, were carried out to test the influence of fish predation on benthic invertebrates, in particular, the larvae of nuisance midges.

Results from the surveys conducted so far showed that each reservoir has a unique community structure and food web, which corresponds to observations from the biomanipulation trial where predator influence was shown to differ between reservoirs. In addition, the population estimates of dominant fish species in reservoirs have been tabulated for the first time.

"Knowledge arising from this project provides an important baseline snapshot of reservoir ecology for long-term monitoring, allowing PUB to monitor how the ecology of their reservoirs evolves and identify any emerging patterns," says Yeo. "The data can also provide a foundation to set the direction for future research such as further investigations on the use of "top-down", food web-based biological measures in our reservoirs."

Researchers and affiliations

D. Yeo, J. Kwik, J. H. Liew | *National University of Singapore*

T. Jardine | *University of Saskatchewan*

J. Lu | *PUB Singapore*

Contact

D. Yeo; dbsyeod@nus.edu.sg

J. Kwik; jkwik@nus.edu.sg

J. H. Liew; jiahuan@nus.edu.sg



MEMBRANE TECHNOLOGY

Membrane technology has played a vital role in the development of NEWater in Singapore. Dating back to 1974 when a demonstration plant was set up to study the feasibility of reclaiming used water using physicochemical processes, the technology has since grown and developed. NEWater is now a key pillar of Singapore's water strategy.

Backed by almost 40 years of experience, Singapore's water researchers continue to explore innovative ways of applying and optimising membrane processes for water and used water treatment.

Improving pre-treatment for seawater reverse osmosis

Testing the use of ceramic membranes in desalination pre-treatment

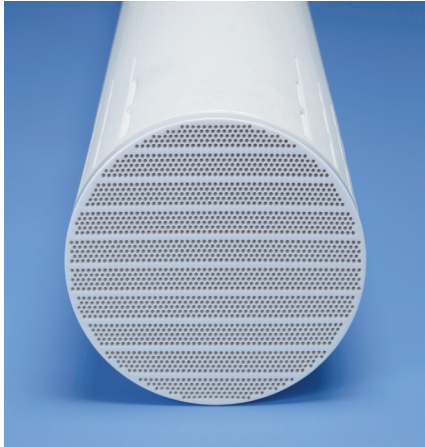

Fig. 1: Ceramic membrane supplied by Metawater

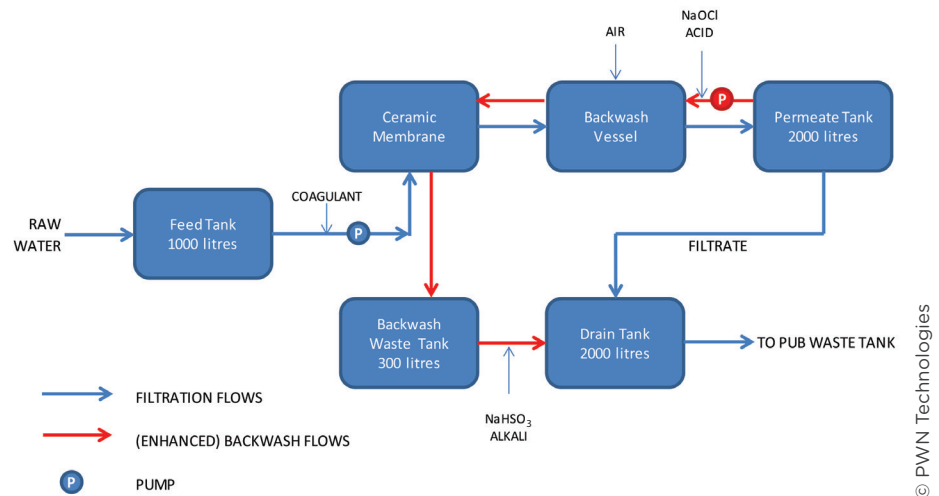

Fig. 2: Process diagram of the filtration process

Desalination is one of the main sources of water supply for Singapore. For reliable, robust and cost-effective desalination through seawater reverse osmosis (SWRO), seawater needs to undergo pre-treatment to prevent biofouling, membrane plugging and scaling. However, conventional methods of pre-treatment for SWRO require a lot of space, and polymeric membranes, which are often used in the pre-treatment process, are prone to fouling because of the deposition and build-up of substances on its surface.

To overcome these limitations, PUB, in conjunction with PWN Technologies and Wabag, tested ceramic membranes supplied by Japanese manufacturer Metawater (Fig. 1) in a four-month trial held at PUB's R&D facility in Tuas.

As ceramic membranes can withstand rigorous cleaning regimes, the frequency of cleaning required is much lower, resulting in less overall downtime and disruptions in operations. Ceramic membranes also allow for higher flux which leads to higher production and lower energy consumption, and have lifespans of 10 to 15 years, compared to five to seven years for polymeric membranes.

"A key advantage of using ceramic membranes as a pre-treatment technology for seawater desalination is that coarse and fine screening upstream is not required, allowing for a more compact and operationally reliable plant," PWN Technologies CEO Jonathan Clement said.

The pilot plant, with a capacity of 200 cubic metres a day, used a single ceramic membrane with a 25 square metre filtration area, 2,000 feed channels with diameters of 2.5 millimetres and a nominal pore size of 0.1 microns. The trial focused on optimising system operations to maximise water recovery and improve the pilot plant's efficiency (Fig. 2). Rigorous analysis of water quality and control of fouling were ensured to optimise pre-treatment conditions, reduce chemical cleaning frequency and chemical consumption, and improve the quality of the filtrate for better RO treatment downstream.

The results indicated that a sustainable flux – a key parameter in determining the quantity of membrane elements required at a full-scale plant – of between 150 and 175 litres per square metre per hour could be achieved with ferric chloride as a coagulant (typically used in SWRO systems to combine smaller particles into larger flocs). PWN Technologies recommends using ferric chloride as it provides better results in terms of transmembrane pressure and has low levels of dissolved coagulant in the filtrate. Additionally, the low silt density index and turbidity values recorded indicate that the filtrate is suitable for the downstream RO process.

Researchers and affiliations

G. Milton | PWN Technologies

L.Z. Zhang | PUB Singapore

Contact

G. Milton; gmilton@pwntechnologies.com

Reducing solids retention time in membrane bioreactor systems

Study aims to evaluate the energy consumption and performance of membrane bioreactor systems operated with a short solids retention time



Fig. 1: A pilot-scale MBR system being evaluated in the study

© National University of Singapore

The membrane bioreactor (MBR) process combines a membrane process, such as ultrafiltration, with a suspended growth bioreactor to enhance the quality of the treated water. The process can yield water that is consistently free of suspended solids and low in organic matter.

To treat used water, MBRs are typically operated at a solids retention time (SRT) of at least 10 days to give the bacteria enough time to break down the raw sewage. However, this leads to a high level of mixed liquor suspended solids (MLSS), a high concentration of microorganisms and non-biodegradable suspended matter in the used water. This causes bulking of solids, and results in increased energy consumption because a higher amount of aeration is required to overcome the reduced air transfer efficiency. Conversely, operating MBRs at shorter SRTs could potentially be more energy efficient because the concentration of MLSS would be lower.

In preparation for the implementation of MBR technology at the future Tuas Water Reclamation Plant (WRP), a team from the National University of Singapore is conducting a series of studies at the Changi WRP using pilot-scale MBRs from suppliers including Sumitomo Electric, Meiden, Mitsubishi Electric, Ceraflo and Evoqua (Fig. 1). They aim to evaluate the energy consumption, fouling characteristics and performance of the various MBR systems when operated at a shorter SRT of about five days.

“It is crucial to understand the operating characteristics of MBR technology running at a short SRT in a full-scale application,” said Ng How Yong, who is leading the study.

Several issues, such as the treatment performance and membrane fouling behaviour of MBR systems when operated at short SRTs, are not yet well understood, Ng explained. For example, the overall nitrogen removal efficiency could be affected due to lower concentrations of MLSS, which provides the electrons to denitrify the oxidised nitrogen recycled from the downstream aerobic zone in the anoxic tank, and high levels of dissolved organic matter in the returned mixed liquor (a combination of used water and biological mass), Ng said.

The study is still ongoing. Ng said his team hopes to assess the fouling characteristics of the membranes from different suppliers, their energy savings potential and most importantly, their consistency in producing high-quality permeate when operating at short SRTs so as to optimise the operating conditions of the pilot MBRs.

Researchers and affiliations

H.Y. Ng, S.L. Ong, K.K. Ng, S.L. Low, S. Huang, A. Liu | *National University of Singapore*

Y.L. Wah, W. Lay, Y. Gu | *PUB Singapore*

Contact

H.Y. Ng; howyongng@nus.edu.sg

Using water treatment technology in the oil & gas industry

GE conducts pilot-scale demonstration of seawater sulphate removal by nanofiltration



Fig. 1: Seawater injection at an offshore oil rig

© GE Water & Process Technologies



Fig. 2: Pilot-scale demonstration set up at PUB's R&D testing facility in Tuas

© GE Water & Process Technologies

Water injection is a process in oil production where seawater is injected into an oil reservoir, usually to increase pressure and stimulate oil production (Fig. 1). However, it is critical to remove sulphates present in the seawater to prevent the scaling of injection and production wells and to minimise reservoir souring due to hydrogen sulphide gas production (a toxic by-product of sulphate respiration by sulphate-reducing bacteria). The most common way of removing sulphate from seawater is by using sulphate removal units (SRUs) consisting of trains of nanofiltration (NF) membranes, as the highly charged surface of the NF membrane rejects divalent ions like sulphate, magnesium and calcium.

Petrobras sought to validate the performance of GE's seawater sulphate reducing (SWSR) NF membrane for its potential use in the company's SRUs. GE's SWSR NF membrane has a lower fouling tendency, translating into longer intervals between cleanings, and excellent salt permeability and divalent ion rejection. A research team from GE led by principal investigator Zamir Alam worked with Petrobras and PUB to conduct a pilot-scale demonstration at PUB's R&D facility at Tuas over a five-month period (Fig. 2) to monitor the performance of the membrane.

The membrane proved resistant to fouling and demonstrated excellent hardness rejection properties, with initial calcium and magnesium hardness rejection levels of about 87% and 95% respectively, which translates into a greater reduction of scale. Based on the results of the study, which was done in accordance with Petrobras guidelines, GE's SWSR NF membranes are technically approved for use, exceeding Petrobras' required sulphate removal threshold of 99.5%.

"The NF pilot study in Singapore confirms the excellent sulphate rejection property of GE's SWSR NF membrane", Zamir said. "Even with very challenging feed water, which has a feed sulphate concentration of around 6,000 parts per million (ppm), the NF membrane showed more than

99.8% sulphate removal. The permeate sulphate level was around 10 ppm," he added.

Commenting on the study, GE Singapore Water Technology Centre director Ashish Aneja said, "PUB's support in providing the facility for the testing of our NF membrane in enhanced oil recovery has been critical in Petrobras' validation and approval of the product. GE plans to continue to test other technologies relevant to the oil and gas industry in the form of pilots, such as the use of ultrafiltration membranes as a pre-treatment technology, and compare it against cartridge filtration. Advancing knowledge in these technologies is also beneficial to PUB as the knowledge gained could also be applied in processes such as seawater desalination."

Researchers and affiliations

Z. Alam, N. Antonopoulos, M. Boczkowski, A. Aneja, M. Soria, B. Rudie, K.H. Wee, V. Ramachandran, N. Moe, P.B. Lorenzo, P. Udhayaragavan, B. Chaudhari, S.A. Khoo | *GE Water & Process Technologies*

J. Thong | *PUB Singapore*

Contact

Z. Alam; Zamir.Alam@ge.com,
M. Boczkowski; matt.boczkowski@ge.com



NETWORK MANAGEMENT

Singapore's water strategy focuses on the management of water resources in an integrated manner across all points of the water loop. In the field of network management, a key aim of water research and development in Singapore is to ensure the delivery of high-quality water from the waterworks to consumers while ensuring the collection and reclamation of used water in an effective and efficient manner.

The management and maintenance of Singapore's water networks is therefore a critical function, as well as a responsibility that spurs Singapore's water researchers to even greater technological innovation.

Smart sensors to monitor toxicants

Exploring the use of integrated microbial electrochemical sensors to help monitor toxicants in used water network in real-time



Fig. 1: MES system installed at Tanjong Penjuru Pumping Station for the field trial

© National University of Singapore



Fig. 2: Compact MES system to be installed at five industrial trade effluent sites

© National University of Singapore

Heavy metal usage in industrial processes can potentially result in the discharge of metal-laden effluents into the used water system, adversely impacting the used water treatment process, for example, through inhibiting microbial growth during the activated sludge process. To prevent or minimise this, toxicity sensors can be placed along the used water network upstream of water reclamation plants (WRP).

A team from the Centre for Water Research at the National University of Singapore (NUS) led by principal investigator Ng How Yong is working with PUB to develop an integrated microbial electrochemical sensor (MES) system as an affordable source control method of monitoring toxicants in the used water network online and in real-time, the first of its kind in the world.

“The MES is very responsive, making the system suitable for detecting accidental or illegal discharges. This allows network and WRP operators to take timely and appropriate measures to protect the downstream biological treatment processes at WRPs,” Ng said. He added that the system can also indirectly safeguard the NEWater treatment process, which uses treated used water from the WRPs.

The sensor is a toxicity sensor developed using microbial fuel cell technology. It works on the principle of bio-electrochemistry, a process in which electrochemically-active bacteria at the anode surface of the sensors metabolise organic compounds to produce electrons. The flow of the electrons between the anode and cathode surfaces through an external circuit of the MES generates an electric current, which is measured as the voltage output. When the bacteria is subjected to toxicants, their electron transport metabolism becomes inhibited, thus causing the voltage signal to drop quickly.

So far, tests have shown the system to be effective, simple to operate and affordable. “It has been reliable in detecting toxic compounds in used water. This should deter breaches of the effluent discharge limit for toxic

compounds and ensure that the used water received by the water reclamation plants is suitable for further biological treatment,” Ng said.

In earlier phases of the project, the MES system was able to detect the presence of individual heavy metals and cyanide in domestic used water during spike tests conducted at NUS’ laboratory. The performance of the MES system was further validated at Tanjong Penjuru Pumping Station (Fig. 1), which receives used water from a catchment covering several industrial estates that include electroplating factories using cyanide and heavy metals in their production processes.

Ng said the next stage of the project is to develop an MES system that is small, portable and easy to install (Fig. 2). The system will be installed and tested at five industrial trade effluent sites.

Researchers and affiliations

H.Y. Ng, S.L. Ong, H.C. Liaw,
S. Kharkwal | *National University of Singapore*

E.K.K. Liau, K.R. Chaudhary, Y.L. Kwok,
Y. Gu | *PUB Singapore*

Contact

H.Y. Ng; howyongng@nus.edu.sg

Encouraging water conservation with smart water meters

PUB trials smart meters to evaluate the effectiveness of automated meter reading in promoting water conservation

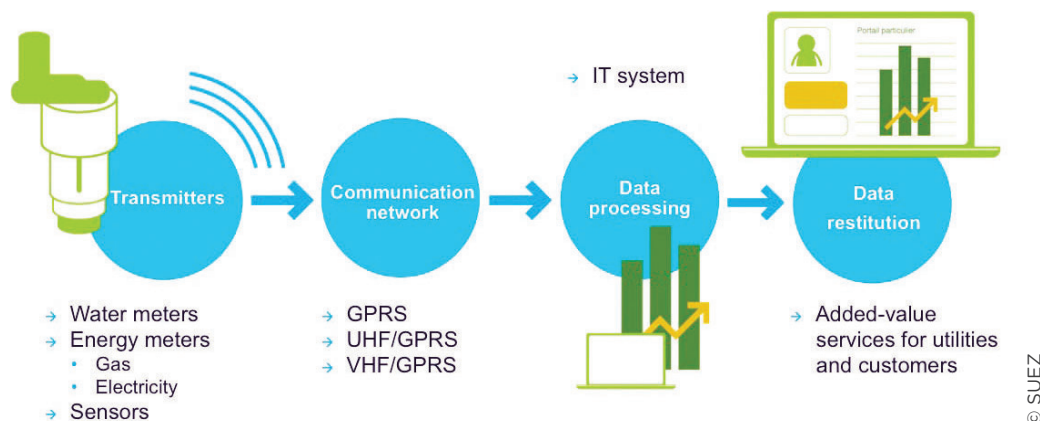

Fig. 1: Water consumption feedback using AMR technology

In recent years, factors such as climate change, population growth and urban development have highlighted the need for more sustainable approaches to urban water management. Automated meter reading (AMR) technology, or smart meters, can provide information on water supply and end-use to support sustainable urban water management efforts.

AMR technology is able to improve the timeliness and accuracy of data as water consumption data is automatically recorded and transferred to utility providers or third parties, with details about the date and time of consumption, as well as the volume of water consumed. Some cities facing water stress use this technology to adjust their prices when demand is very high, or to target specific end uses (water consumed for a specific activity, or by a particular appliance), which is critical in refining demand forecasting models and developing more effective strategies for sustainable water use. Smart meters also have benefits for both water companies and customers, such as better identification of water losses within the system network, reduced plumbing leak losses, verification of conservation investments and timely notification of water conservation efforts.

While the technology has been driven by the desire for more information on time of use and end use, as well as its ability to reduce labour costs for meter reading, PUB also sees the potential to use the technology to prompt changes in the way domestic customers use water and promote individual responsibility. It hopes to do this by providing household consumers access to timely, relevant and comprehensible information that can assist daily decisions on water use.

PUB is developing the AMR infrastructure in Singapore with the help of French waste and water management firm SUEZ as part of the Automated Meter Reading Project supported by the TechPioneer grant. During the 2.5-year project, SUEZ and PUB will collect detailed data on household water consumption to build customer

consumption profiles and identify consumption patterns and trends. The data will then be analysed and provided to customers, enabling them to monitor their water usage patterns and better manage water consumption (Fig. 1). In addition, PUB will also customise its engagement strategies to incentivise customers towards doing more to conserve water, such as by setting water saving goals and tracking the efficiency of their water usage based on their consumption profiles.

SUEZ project manager Benjamin Evain pointed out that the use of smart meters also allows water companies to introduce mechanisms, such as elements of game playing (gamification), to engage and motivate customers toward water conservation, which could be more effective than increasing tariffs.

This research is co-funded by PUB and the Singapore National Research Foundation under its Technology Pioneer (TechPioneer) grant. The grant is administered by PUB and the Singapore Economic Development Board (EDB).

Researchers and affiliations

J. Batisse, K. Claudio | *Le LyRE, France*

B. Evain | *SUEZ*

Y.L. Soh, K.J. Zhou | *PUB Singapore*

Contact

B. Evain; benjamin.evain@suez.com

Modelling efficient sewer networks using GIS

Developing Geographical Information System tools to improve sewer network planning and design

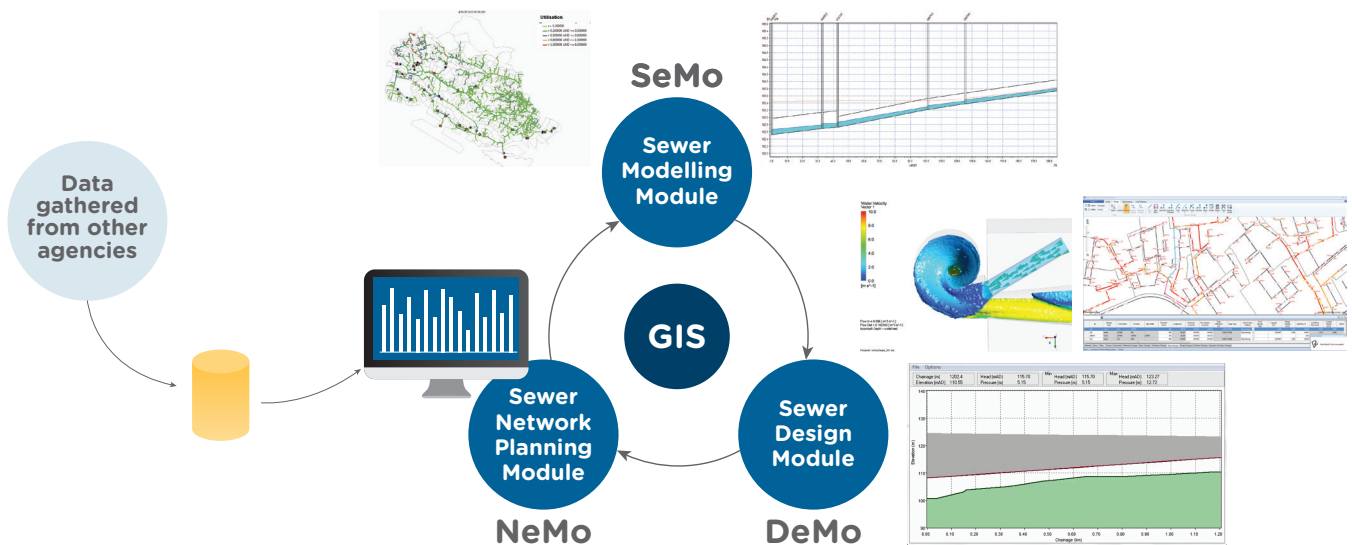

Fig. 1: The three planning modules: NeMo, SeMo and DeMo

As Singapore's water authority, PUB regularly reviews development plans by public development and planning agencies to align the provision of used water facilities with planned developments. An efficient system is required to keep track of changes, check the adequacy of the existing network, and plan enhancements to ensure that new developments are adequately served by the water loop in a timely manner.

With the upgrading of traditional mapping data to a Geographic Information System (GIS) database, PUB has developed a Sewer Network Planning Module, simply named "NeMo", to replace older in-house assessment tools that depended on spreadsheets and computer-aided drafting and design (CADD) files to estimate the used water generated from any land use or development activity. Besides estimating the amount of used water generated from a development, NeMo also contains information on Singapore's sewer network, developments served, used water generation parameters, water usage, and more. This helps engineers carry out quick network capacity checks for new developments, and is PUB's main GIS tool for sewer network planning.

This was followed by the development of a Sewer Modelling Module (SeMo) and Sewer Design Module (DeMo) by PUB with engineering consultants Black & Veatch and DHI. Both modules are tightly integrated with NeMo's database and are used as primary engineering tools in the planning and design of sewers. In addition, the calibrated sewer network models in SeMo are capable of simulating the sewer network's performance according to different planning scenarios, taking into account different types of environmental and urban development changes.

At the core of SeMo is a library of about 60 sewer network models representing different planning base years and horizons, allowing the health of existing and future sewer networks to be closely monitored. The models are stored in a Model Catalogue server created to manage the synchronisation of databases between NeMo and SeMo/

DeMo. Planning and development data captured in NeMo, with the proposed changes in land use and development, are synchronised with SeMo to update the sewer models seamlessly, so that the modules continue to evolve alongside developmental changes over the long term.

SeMo is able to confirm the performance of the used water network. When additional sewers are required, solutions are designed using DeMo, a complete sewer design package developed from the ground up by PUB and their engineering consultants. The package models the solution as it is created and also contains in-house protocols on sewer network design and the cost database of used water elements, allowing catchment engineers to have access to different used water network options and their implementation costs.

PUB will continue to upgrade these modules to support the planning workflow processes of engineers and to provide operational analytics and modelling modules to enhance the agency's sewer planning and ground maintenance operations.

Researchers and affiliations

C.H. Tan, H.L. Ong, M.S. Woo, J.C.G. Ang, M.C. Thong, D.D. Zhang, S. Zheng, T. Ravichanthiran | *PUB Singapore*

J. Lau, C. La Verghetta, Y.Y. Neoh, S. Hernani, Y. Liang | *Black & Veatch (SEA) Pte Ltd*

V. Phipatanasuphorn, M.A.T. De Sales, L. Yde, C. Sarpin, C.M. Cheong, G.T. Philip | *DHI Water & Environment (S) Pte Ltd*

Contact

T.C. Hoon; tan_chee_hoon@pub.gov.sg
J.C.G. Ang; ang_chai_geok@pub.gov.sg



USED WATER TREATMENT

Singapore's research in used water treatment focuses on closing the water loop to short-circuit the water cycle. Instead of discharging treated used water into the sea and relying on the natural hydrologic cycle of evaporation, cloud formation and rainfall to recycle the water, Singapore's water scientists intervene to close the water loop by reclaiming used water and distributing it for large-scale non-potable use by industry, as well as for indirect potable use.

To do this, Singapore's water scientists work to develop innovative, cost-effective and efficient processes using technologies for sludge minimisation, biogas utilisation and odour destruction that can achieve high quality effluent.

Determining anaerobic biodegradability of enhanced primary sludge

Determining the feasibility of biosorption pre-treatment for enhanced energy generation

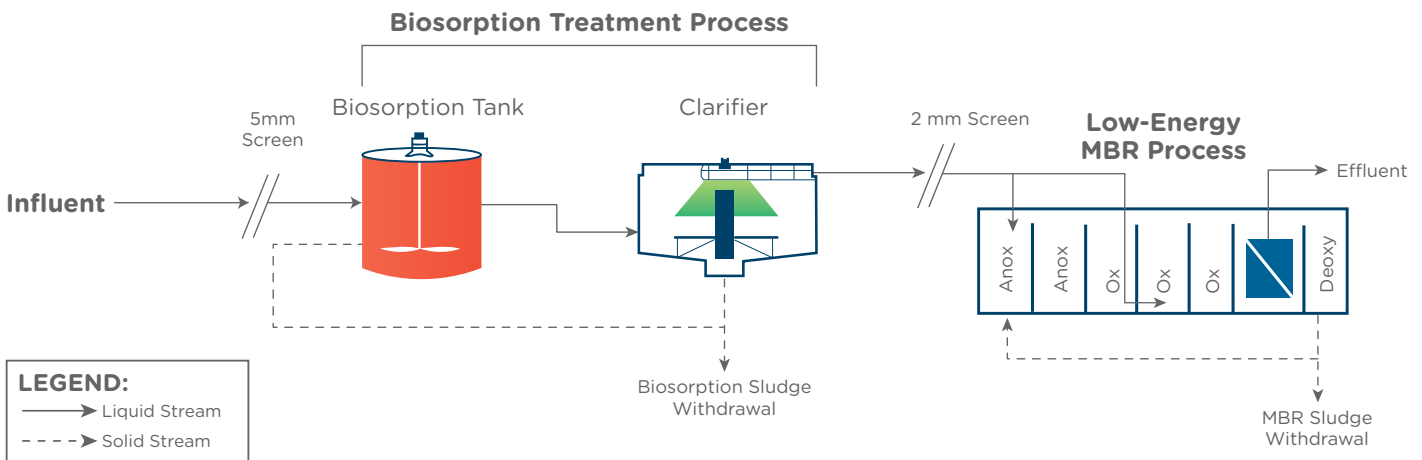

Fig. 1: Schematic of the biosorption-low-energy MBR process at the IVP

With an increasing focus on achieving energy self-sufficiency in used water treatment, new technologies to recover energy from organic material in used water are being explored. One possibility is to put sludge through a biosorption treatment followed by a low-energy membrane bioreactor (MBR) (Fig. 1) to achieve energy and cost efficiencies. This biosorption-low-energy MBR process is being tested at an integrated validation plant (IVP) located within the Ulu Pandan Water Reclamation Plant (WRP).

Used water contains organic carbon compounds which need to be removed from the final effluent water. The biosorption process improves upon the conventional primary clarifier system by enhancing the capture of influent organics to produce the primary sludge. This reduces the organic loading at the downstream low-energy MBR process, resulting in less aeration requirements and thus lower energy consumption. Furthermore, the larger amount of organics captured in the sludge from the biosorption process can be converted into methane through anaerobic digestion, so more energy can be produced and reused. This combination of lower aeration requirements in the low-energy MBR process and increased electricity generation results in an overall increase in energy efficiency.

However, most information currently available on biosorption treatment performance were referenced from plants that operate in temperate countries. There is still insufficient information about the anaerobic biodegradability of local primary sludge obtained from the biosorption process, which differs compositionally from its foreign counterparts, under Singapore's tropical conditions. It is also critically important to ascertain how the anaerobic biodegradability of sludge obtained from the biosorption treatment compares against that of the low-energy MBR process and conventional used water treatment.

One way to compare the difference in sludge properties is the use of the Biochemical Methane Potential (BMP) test, which measures the potential volume of methane produced per gram of volatile solids destroyed, and thus the potential amount of electrical energy that can be generated. PUB has collaborated with the Nanyang Environment and Water Research Institute to conduct BMP measurements on different sludge samples, including samples from the biosorption process of the IVP, a biosorption pilot plant at Jurong WRP (mix of industrial and domestic used water), and the primary clarifiers at Ulu Pandan WRP (primarily domestic used water).

The results showed that more methane can be produced from sludge from the biosorption process compared to that obtained from the low-energy MBR process, and the overall data suggests that it may be feasible to enhance carbon/energy capture from organics in used water through the biosorption-low-energy MBR process at water reclamation plants here.

"In addition to understanding the BMP of the biosorption-low-energy MBR process when it is running at full-scale, the study also gave plant operators the knowledge and understanding of how to optimise methane production, and will aid in the design of the anaerobic digestion system to optimise biogas production at the future Tuas WRP," principal investigator Ng Wun Jern said.

Researchers and affiliations

W.J. Ng | *Nanyang Technological University*

G. Tao, Y. Lee | *PUB Singapore*

Contact

W.J. Ng; wjng@ntu.edu.sg

Testing advanced used water treatment processes

Demonstration plant at Ulu Pandan will test advanced used water treatment processes for future use at full-scale

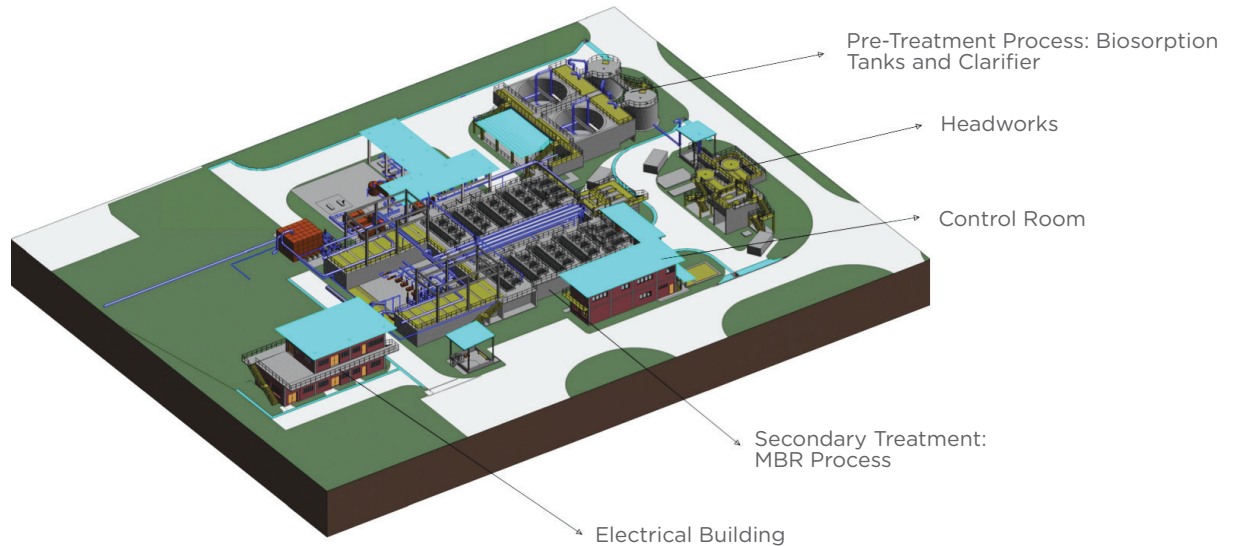

Fig. 1: The proposed model of the demonstration plant under construction at Ulu Pandan WRP

Within the next 10 years, the Tuas Water Reclamation Plant (WRP) will be constructed as part of Phase 2 of the Deep Tunnel Sewage System (DTSS) that will meet Singapore's used water collection, treatment and disposal needs. It will include an integrated NEWater factory and will feature advanced technologies to increase energy efficiency and reduce manpower demands.

To test the reliability of different instruments, sensors, equipment and treatment processes to be used at Tuas WRP, PUB has commissioned Mitsubishi Corporation to build a 2.75 million gallons per day (MGD) demonstration plant at Ulu Pandan WRP. The demonstration plant is slated for completion in early 2017.

"The demonstration plant will also enable PUB operators to optimise automated treatment processes on a larger scale and will give them experience in running and maintaining a plant that incorporates a range of advanced water treatment technologies," PUB's Guihe Tao said, speaking about plans for the plant.

Data from a 0.22 MGD integrated validation plant (IVP), which has been operating at Ulu Pandan WRP since January 2014 to test the effectiveness of various liquid treatment options, was used to design the highly automated demonstration plant (Fig. 1). Based on the results of the IVP study, selected liquid treatment streams will be implemented in the demonstration plant. While the treated water from the demonstration plant will mostly be sent for industrial use, portions of it will be sent to a pilot reverse osmosis unit to verify if the effluent meets NEWater specifications.

The demonstration plant will also include features that are not used in conventional treatment processes, such as a biosorption unit to increase the recovery of organic compounds in used water, a mixed liquor fermenter to

treat influent phosphorous and a five-pass step feed. A membrane bioreactor (MBR) that is more robust and easier to operate will also be incorporated in place of the final sedimentation tank that is used in conventional used water treatment. With these new technologies, PUB hopes to improve the removal of phosphorus and nitrogen in used water and reduce sludge retention time from 10 days to just five, such that the plant's treatment efficiency can be improved with less bacteria and air consumption needed to treat the used water.

"By running the demonstration plant, we hope to mitigate operating risks and incorporate design enhancements into the final design of the Tuas WRP. A pool of operators will also be trained at the demonstration plant and they will be deployed to Tuas WRP when it opens," Tao said.

Tuas WRP will be able to treat both municipal and industrial streams of used water separately, and will have a total treatment capacity of 176 MGD.

Researchers and affiliations

G. Tao, J.T. Yen | *PUB Singapore*

Contact

G. Tao; tao_guihe@pub.gov.sg

Increasing energy recovery in anaerobic digestion

Demonstration plant to add food waste to used water sludge digestion for increased biogas production

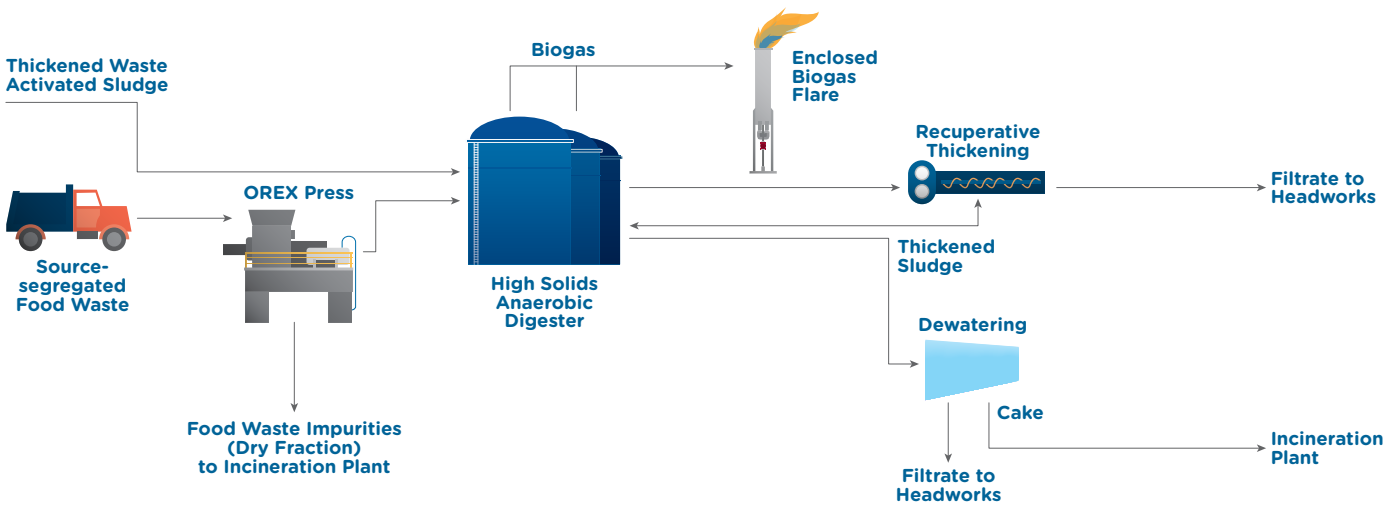

© Anaergia Singapore Pte Ltd

Fig. 1: The OMNIVORE™ process (patented by Anaergia) to be demonstrated at Ulu Pandan WRP

Anaerobic digestion (AD) is a biological process in which microorganisms breakdown biodegradable material in the absence of oxygen, producing biogas. This process is applied in the treatment of used water sludge at PUB's water reclamation plants (WRPs). The biogas produced provides part of the energy used to operate the plants, while the residual sludge is dewatered and subsequently sent for incineration.

The biogas produced from this process currently supplies about 20% to 25% of the total energy consumption of WRPs. PUB hopes that by adding food waste to used water sludge, the higher calorific value of food waste can double the amount of biogas produced.

It will test this process at a 2,000 square metre co-digestion facility, currently under construction, at the Ulu Pandan WRP. The facility will treat up to 40 tons of combined food waste and used water sludge daily using a process patented by Anaergia (Fig. 1). It will receive about 15 to 20 tons of food waste daily from locations in the Clementi district, including hospitals, camps and schools, which is mixed with 20 tons of used water sludge from Ulu Pandan WRP.

In the co-digestion process, sludge in the anaerobic digester is continuously thickened by removing water and concentrating the solids content of the biomass (a mixture of food waste and sludge), and recycling it back into the digester. This process enhances the biological digestion process, thereby improving efficiency and performance of the digester to increase the amount of biogas produced. In addition, the co-digestion of food waste and sludge separates food waste from other dry recyclable waste, facilitating the downstream recycling process.

“We expect to achieve at least a 50% increase in biogas with the addition of food waste in the AD process. This will generate more electricity for process usage, and is aligned to PUB's long-term strategy of achieving energy self-

sufficiency for used water treatment processes,” Anaergia project manager Emanuele de Angeli said.

According to estimates by the National Environment Agency, only 13% of food waste, which accounts for about 10% of Singapore's total waste, was recycled in 2014, with the rest ending up in landfills or incinerated. As such, the co-digestion process has the potential to significantly reduce waste and increase energy production.

According to Anaergia, the results of the trial will validate the efficacy and cost-effectiveness of co-digestion in Singapore. If successful, this process can potentially be considered and implemented at the future Tuas WRP and NEA's Integrated Waste Management Facility.

This research is co-funded by PUB and the Singapore National Research Foundation under its Technology Pioneer (TechPioneer) grant. The grant is administered by PUB and the Singapore Economic Development Board (EDB).

Researchers and affiliations

E. de Angeli | Anaergia Singapore Pte Ltd

J. Ng | PUB Singapore

Contact

E. de Angeli; emanuele.deangeli@anaergia.com



WATER QUALITY AND SECURITY

As in any country, the quality and security of the water supply is of utmost importance. In order to deal with sources of contamination, Singapore's water scientists constantly strive to improve water quality sampling methodologies through continual innovation in biological and chemical detection methods with one goal in mind: to achieve better, safer and a more secure supply of water.

Using the Fish Activity Monitoring System to monitor raw reservoir water

PUB and ZWEEC Analytics test the Fish Activity Monitoring System fitted with an additional filtration module



Fig. 1: Test-bedding setup of FAMS Gen2 at CCKWW



Fig. 2: Pre-filtration module of FAMS Gen2 with backwash mechanism for test-bedding at JRWW

One of the ways PUB monitors the toxicity of water in the water loop is by measuring the behavioural responses of a group of fish and their mortality rate when this water is passed through them. The system, known as the Fish Activity Monitoring System (FAMS), is an automated device that combines video cameras with image analysis software to analyse fish behaviour and survival, and alerts operators if there are deduced changes in water quality. It has been deployed at waterworks and service reservoirs since 2011 to monitor the quality of treated water. However, the ability of the system to monitor the quality of raw water has been limited because unlike treated water, raw water has higher concentrations of algae and suspended solids, preventing the video technology software from performing optimally.

ZWEEC Analytics and PUB conducted a pilot test-bedding of the second generation of FAMS (FAMS Gen2), which adds a ceramic filtration module to the system to overcome the limitations of its predecessor. The filtration module removes particles from the water before it enters the fish tank, ensuring good visual clarity for the analytic module to perform optimally.

The system was tested at two locations, Choa Chu Kang Waterworks (CCKWW) (Fig. 1) and Johor River Waterworks (JRWW) (Fig. 2), to monitor its performance in addressing high algae and high turbidity issues respectively, and to assess the reliability and maintenance frequency of the system's filtration module.

The units were left running continuously, with manual checks made fortnightly. The filtration module's output rate was logged along with turbidity levels before and after the filtration module. In addition, the system was equipped with a backwash mechanism with a 30-minute filtration period so its maintenance frequency could be kept low.

The system was able to run continuously without any manual maintenance required for an extended period of

two months, and was capable of working in algae-prone conditions with minimal maintenance. Chemical analysis on the pre- and post-filtered water showed that the filtration module did not remove soluble toxicants, so the fish can still be monitored for behavioural changes due to changing toxicity levels.

“The test-bedding results are promising and show that FAMS Gen2 has the potential to be deployed as the first line of defence in detecting potential contaminants in raw reservoir water before treatment, an improvement over the existing practice of only deploying FAMS after the water treatment process in a waterworks,” ZWEEC Analytics' Eng How Lung said.

Researchers and affiliations

H.L. Eng, Y.H. Soe, K.Y. Sim, E. Ong | ZWEEC Analytics

Q. Lu, Y.T. Wong, M. Tay, M.Y. Yap, I. Tay, A.C. Ting, R. Xie | PUB Singapore

Contact

H.L. Eng; howlungeng@zweec.com
Q. Lu; lu_qinglin@pub.gov.sg

Optimising flow cytometry protocols to monitor water quality

Testing flow cytometry for faster and more accurate detection of microbes in treated water

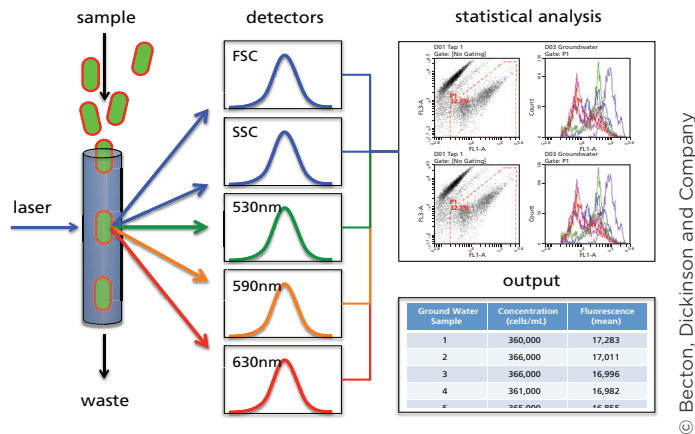

Fig. 1: How flow cytometry works

In Singapore, water treatment plants use a combination of processes to remove microorganisms present in raw water. After treatment, the use of chloramine helps to prevent microbial regrowth in the treated water. While the chance of microbial regrowth is usually small, it can be triggered by suitable temperatures, availability of nutrients and the lack of a residual disinfectant. Microbial regrowth can potentially alter the taste and odour of drinking water.

Typically, a culture-based method known as the heterotrophic plate count procedure is used to test for microorganisms in treated water. The process takes 48 hours as the bacteria needs to be cultured before it can be quantified. Furthermore, only a small population of the total bacterial cells present in a water sample can be detected using this method as the majority of bacteria cells cannot be readily cultivated. Because of such limitations, researchers have been looking for more rapid and accurate ways of quantifying microbes in drinking water.

One way is using flow cytometry, which is the process of passing thousands of cells through a laser beam in a controlled and focused manner (Fig. 1) to produce signals from the scattered light. These signals are then digitised for computational analysis. Comprehensive information about the bacteria's cell size, granularity and fluorescence, which reflect the DNA content of the cells, as well as the viability of each cell, can be obtained quickly this way. Flow cytometry also eliminates the possibility of manual counting errors and allows microorganisms to be quantified within minutes.

To enable the widespread adoption of flow cytometry in water testing processes, PUB is currently working with Becton, Dickinson and Company (BD) to develop standardised procedures for using the BD Accuri C6 flow cytometer. In a test-bedding project, the research team established and optimised working protocols for enumerating microorganisms in water samples taken from more than 100 locations. At the same time, they measured

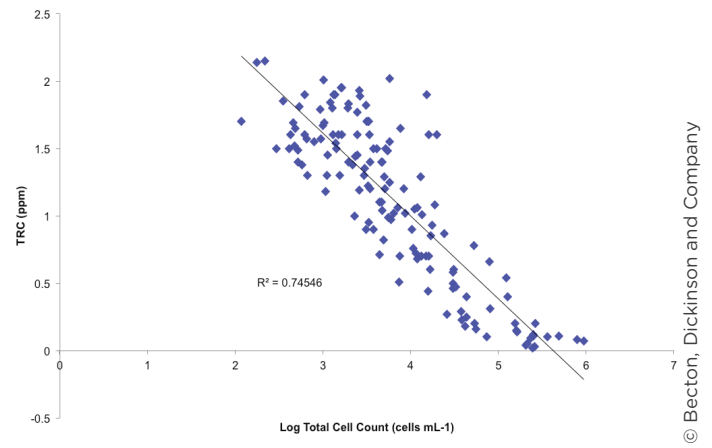

Fig. 2: Correlation between total residual chlorine (TRC) and total cell count as counted by flow cytometry

the total residual chlorine (TRC) of the samples, which is known to inversely correlate with total cell counts (Fig. 2). The results from the samples showed that the bacterial count went down as the TRC levels increased.

"This is proof of concept that flow cytometry is suitable for measuring bacterial cell count," Chee explained. He added that further research is being conducted on using flow cytometry to study the efficiency of chlorination, ozonation and reverse osmosis in water treatment.

Researchers and affiliations

K.Z.J. Chee | Becton, Dickinson and Company

Z. Hou | PUB Singapore

Contact

K.Z.J. Chee; Keefe_Chee@bd.com

Hyperspectral monitoring of surface water bodies in real time

Testing the use of hand-held radiometers for more accurate estimates of phytoplankton in reservoirs



Fig. 1: Testing the WISP-3 hand-held radiometer at a reservoir

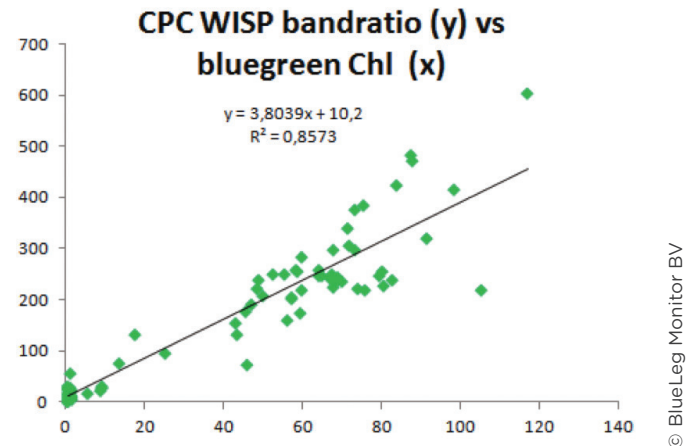

Fig. 2: Correlation between chlorophyll-a data from WISP-3 and from laboratory results

With climate change increasing the risk of floods or prolonged droughts, shifting nutrient balances in water bodies as a result of changes in volume (among others) could favour the growth of certain types of organisms, such as phytoplankton, which mainly comprise green algae and cyanobacteria. High cyanobacteria concentration in reservoirs could result in the formation of aesthetically unpleasant algae scum. Consequently, there is a need to provide timely information on phytoplankton concentrations and increase water monitoring activities to not only protect drinking water supply sources, but also prevent production problems in downstream water treatment processes caused by excessive algae scum.

To this end, PUB has been working with BlueLeg Monitor to test the applicability and accuracy of real-time optical hyperspectral monitoring at surface water bodies, using the WISP-3 hand-held radiometer (Fig. 1), which can determine surface water quality on the spot by analysing the characteristics of the water's colour spectrum.

The WISP-3 radiometer is able to capture the reflectance spectrum of the water body and determine the concentrations of water quality parameters in seconds. Currently, it is able to analyse parameters such as chlorophyll-a, phycocyanin (a cyanobacteria pigment), vertical extinction coefficient (Kd), coloured dissolved organic matter (the optically measurable component of the dissolved organic matter in water) and total suspended matter, indicators of phytoplankton levels in water.

“The measurement of these water quality parameters was traditionally elaborate, complicated and time-consuming. However, the WISP-3 hand-held radiometer is easy to operate with simple training, and can provide quick and reliable results,” principal investigator Hans Wouters said. “Expected benefits of using such hyperspectral field monitors are the potential cost savings on laboratory analysis and field sampling, and the possibility of early warnings for algal blooms, so that mitigating actions can be taken in time,” he added.

Over a six-month project period, the WISP-3 was used to identify the spatial and temporal variations in a number of water quality parameters at several freshwater reservoirs in Singapore. So far, PUB has gathered a large, good-quality dataset of over 1,200 readings, and while the research is still ongoing, initial results, such as that for chlorophyll (Fig. 2), have shown good correlations between the WISP-3 data and laboratory data. More data is still being gathered to determine the correlations between WISP-3 readings, laboratory results and results from field instruments.

“With regular optical monitoring, we should be able to quickly respond to phytoplankton levels in surface water bodies, in particular, to detect the presence of and increasing concentrations of cyanobacteria,” Wouters said.

Researchers and affiliations

J.W. Wouters, C. van Brunschot | *BlueLeg Monitor BV*

S. Peters, A. Hommersom | *Water Insight BV*

Contact

J.W. Wouters; h.wouters@bluelegmonitor.com



WATER TREATMENT

Singapore is committed to ensuring a safe and adequate supply of drinking water for its people. To this end, the development of new technologies to improve water treatment processes for the production of drinking water is of utmost importance. Singapore's water scientists carry out innovative research and development aimed at reducing energy and chemical consumption, and identifying alternative sources of water. This will help to increase supply and safeguard the sustainability of Singapore's water resources for generations to come.

Reducing algae in freshwater feeds at waterworks

Evaluating the effectiveness of upstream automatic screen filters in reducing algae in freshwater feeds at waterworks



Fig. 1: Pilot unit at the pumping station in Kranji



Fig. 2: The Filtersafe strainer basket

Algal blooms in freshwater reservoirs can overload water treatment units, such as media filters and membrane filters, which typically form the pre-treatment processes at waterworks. This can lead to a reduction in the output of treated water and an increase in membrane fouling. Technologies to reduce algae from feed water before it reaches downstream water treatment units, such as dissolved air flotation, microfiltration (MF) and ultrafiltration (UF), exist but they increase system complexity and require the use of strainers to protect the polymeric fibres used in these processes from physical damage.

As such, PUB has been exploring the use of upstream automatic screen filters, or auto-strainers, as a pre-treatment. It is testing the Filtersafe, an auto-strainer manufactured by Kupps & Sachs with four sintered, stainless steel screen layers and a weave-wire mesh, at a pumping station in Kranji (Fig. 1 and Fig. 2). Filtersafe was selected as it boasts high sediment removal rates and has an automatic self-cleaning mechanism, thus allowing for continuous use.

“Preliminary projections show that such strainers could have advantages over other forms of pre-treatment in terms of removing algae from feed water more effectively,” PUB senior engineer Jason Wong said, adding that auto-strainers can enhance the reduction of algal loads on the MF/UF process if used as a first step, therefore reducing the fouling of membranes.

To evaluate the use of Filtersafe as a pre-treatment, the auto-strainers with screens of different mesh sizes were rigorously tested using freshwater drawn from Kranji Reservoir, upstream of the pumping station’s coarse screens. In self-cleaning basket strainers such as this one, a pressure difference between the inlet and outlet is created when the strainer gets clogged, triggering its backwash mechanism to remove suspended solids that accumulate on the screen’s inner surface. As such, no additional flushing pump was used during testing and

the strainer filtered the feed water concurrently with the backwash step.

While using a 40-micron screen did not significantly affect the removal of chlorophyll-a (an indirect measurement of algae), chlorophyll levels in the filtrate fell when a 25-micron and 10-micron screen was used. In particular, the 25-micron screen had a removal rate of 10.6% to 54.6%, while the 10-micron screen had a removal rate of between 34.7% and 45.7%. However, the downside of using finer screens is that the system would have to be operated with a lower throughput, meaning less water can be filtered within the same period of time.

“We are evaluating what the next step should be and we are keeping our options open,” Wong said.

Researchers and affiliations

J. Wong | *PUB Singapore*

E. Woo | *Kupps & Sachs*

Contact

J. Wong; jason_ms_wong@pub.gov.sg

Using electrodialysis for low-energy municipal desalination

Demonstrating the potential of electrodialysis technology at a new pilot plant in Tuas

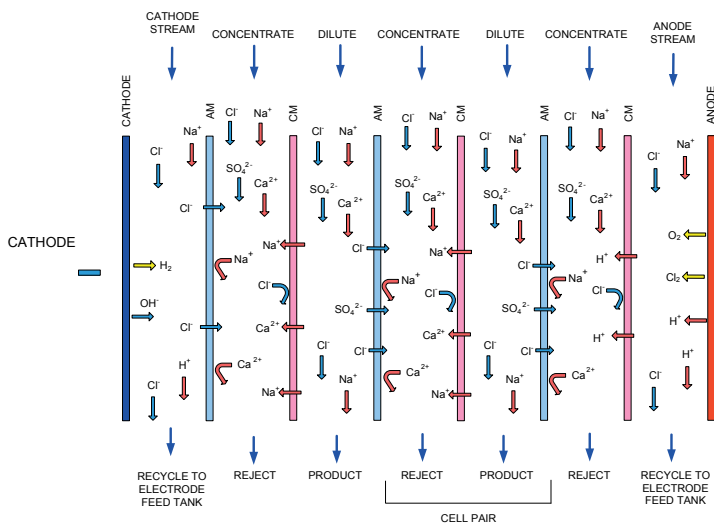

Fig. 1: The ED process to be tested at PUB's R&D facility in Tuas

Desalinated water is crucial to helping Singapore ensure water sustainability. Conventional seawater reverse osmosis (SWRO) processes use up to 3.5 kilowatt hours of energy to produce a cubic metre of desalinated water. With rising energy costs and desalinated water expected to meet a greater percentage of Singapore's water demand in future, there is an urgent need to explore innovative ways to reduce the amount of energy used for seawater desalination.

Instead of pushing seawater through dense membranes to remove the dissolved salt ions, another option could be to use electricity to treat seawater, a process known as electrodialysis (ED). ED is an electrochemical process in which salt ions, which carry either a positive or negative charge, are removed from water when they are attracted to electrodes of the opposite charge. In the process, ions selectively pass through alternating ion-exchange membranes (anionic and cationic) to create separate streams of purified and concentrated water (Fig. 1). The electrochemical concept of moving salts across an electric field uses much less energy than pumping large volumes of seawater through RO membranes under high pressure.

Evoqua Water Technologies is designing and constructing a feed plant at the PUB R&D facility that is able to treat 1 million gallons per day using its Nexed ED technology (Fig. 2). Compared to conventional SWRO, Nexed modules provide consistent water quality with variable feed water parameters or partial removal of contaminants without the need for blending. Because output quality can be manipulated by input power adjustments, this means that energy consumption, operating costs and the space required for SWRO can be reduced significantly. The system is also modular in design and thus fully scalable.

“The Nexed system represents a breakthrough in electrochemical desalination. We are now able to make low-cost, effective and reliable desalination possible. Nexed modules can be applied to a wide range of uses, including

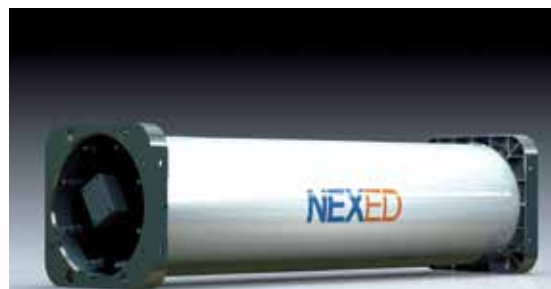

Fig. 2: Evoqua Water Technologies' Nexed ED Module

sea and brackish water, variable salinity applications, and water reuse options,” Evoqua Water Technologies CEO Ron Keating said.

The flow rate at the plant will be gradually increased in 2017 after the first feed flow system of 90 cubic metres per hour is installed in mid-2016. During this period, Evoqua Water Technologies will focus on improving the technology's operational performance and reliability through proper process design and optimisation while demonstrating its potential, the company announced in a press release.

This research is co-funded by PUB and the Singapore National Research Foundation under its Technology Pioneer (TechPioneer) grant. The grant is administered by PUB and the Singapore Economic Development Board (EDB).

Researchers and affiliations

M.J. Shaw, L.S. Liang, K.H. Yeo, X.Y. Qiao, A. Han | *Evoqua Water Technologies*

R. Sih | *PUB Singapore*

Contact

M.J. Shaw; michael.j.shaw@evoqua.com
X.Y. Qiao; xiangyi.qiao@evoqua.com

Optimising biologically activated carbon filters

Pilot plant to conduct filter media tests to improve operations at Johor River Waterworks

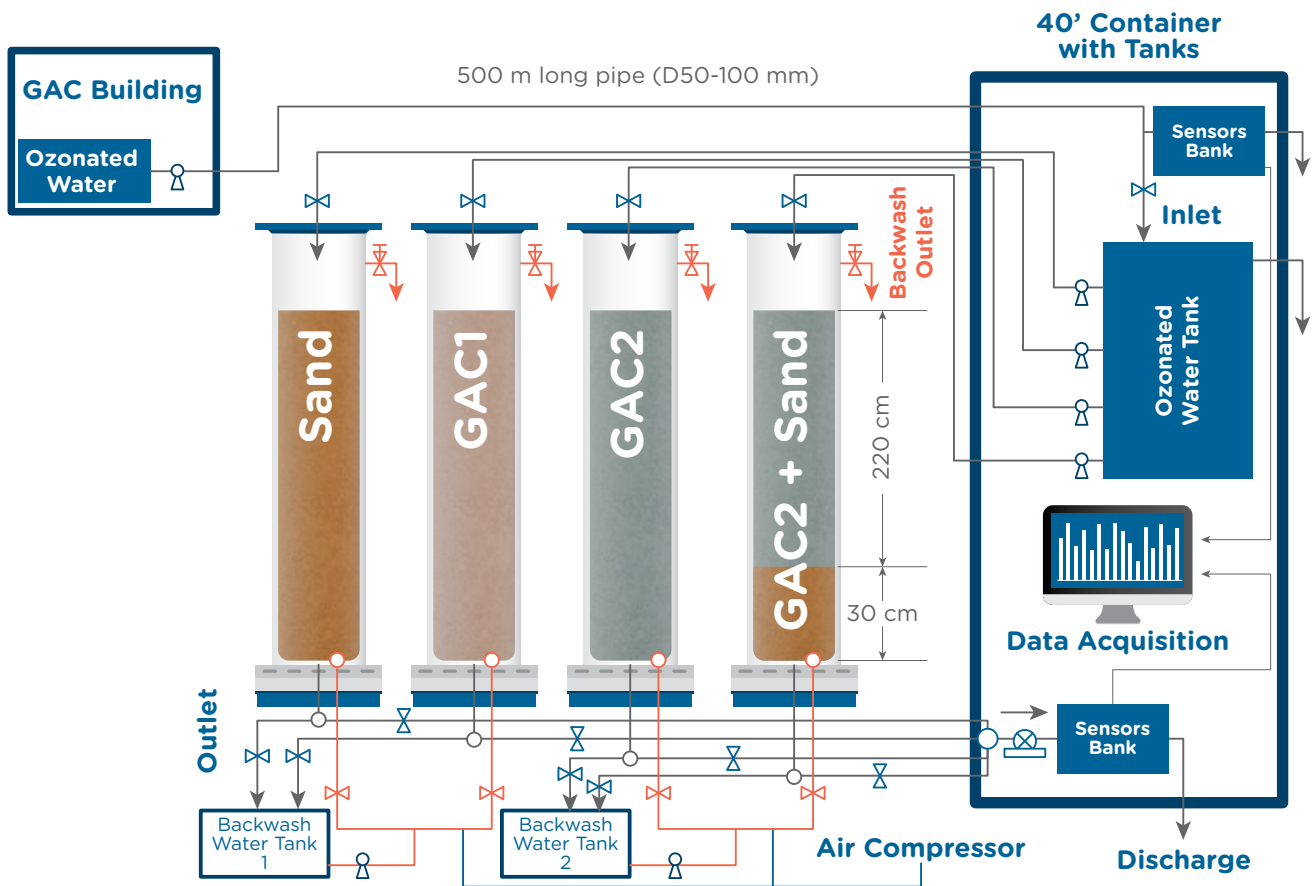

Fig. 1: Schematic drawing of the biological activated carbon pilot plant (GAC1 = granular activated carbon type 1; GAC2 = granular activated carbon type 2)

Ozonation is a water treatment process used to eliminate a variety of bacteria, microorganisms and taste and odour problems in water through an infusion of ozone. However, this process produces biologically unstable water that is high in assimilable organic carbon (AOC) – a source of carbon and energy for bacteria – and could encourage bacteria growth. The most effective and efficient method of removing AOC from ozonated water before it enters the distribution network is by passing it through a filter containing granular activated carbon (GAC). GAC is made of raw organic materials that are high in carbon and is commonly used to remove natural organic compounds, taste and odour compounds, and synthetic chemicals during water treatment by trapping (adsorbing) them in the filter. The combination of ozonation followed by filtration using GAC is commonly known as the biological activated carbon (BAC) filter process.

Hoping to improve BAC filter operations at Johor River Waterworks (JRWW), PUB commissioned a BAC filter pilot plant to conduct a variety of BAC filter media tests. The pilot plant, which was completed in March 2015, feeds ozonated water into four filtration columns, each filled with different filter media, including the mix currently used at JRWW (Fig. 1). The filter media were allowed to stabilise for a few months for acclimation, after which tests were conducted to assess and compare their effectiveness in terms of removing total organic carbon (TOC), AOC and substances such as iron and manganese from water.

The other objectives of the pilot study are to evaluate the effect of empty bed contact time (EBCT) – the time the water is in contact with the GAC filter – on the performance of BAC filters; to identify the optimum backwash scheme for the BAC filters; and to study the estimated lifespan of a BAC filter and determine the parameters that trigger BAC media replacement.

“The effect different EBCTs have on the removal of TOC and AOC is critical as this directly impacts the design and footprint of biofilters for future full-scale applications,” PUB project manager Yongjie Xing explained, adding that he hopes to determine the most efficient and cost-effective EBCT for JRWW.

Xing said the project is still ongoing and more extensive tests will be carried out. “These data will be invaluable for the upgrading of other waterworks in the future,” he said.

Researchers and affiliations

Y.J. Xing, Q.W. Chow, M.Y. Yap, R.J. Xie | PUB Singapore

Contact

Y.J. Xing: xing_yongjie@pub.gov.sg

PUB collaborators

Universities, research centres and international organisations

- Advanced Environmental Biotechnology Centre Singapore
- Agency for Science, Technology and Research Singapore
- American Water Works Association USA
- Canadian Water Network Canada
- Centre for Environmental Sensing and Modeling Singapore
- Centre for Remote Imaging, Sensing and Processing Singapore
- Centre for Water Research Australia
- Cooperative Research Centres Australia
- Delft University of Technology Netherlands
- Deltares Netherlands
- DHI-NTU Water and Environment Research Centre Singapore
- DVGW-TZW Water Technology Center Germany
- Global Water Research Coalition Netherlands
- Imperial College London UK
- International Desalination Association USA
- International Water Association UK
- International Water Resources Association USA
- KAUST Water Desalination and Reuse Center Saudi Arabia
- KWR Watercycle Research Institute Netherlands
- Massachusetts Institute of Technology USA
- Michigan State University USA
- Monash University Australia
- Nanyang Environment and Water Research Institute Singapore
- Nanyang Technological University Singapore
- National Centre of Excellence in Desalination Australia
- National University of Singapore Singapore
- New Energy and Industrial Technology Development Organisation Japan
- Ngee Ann Polytechnic Centre of Innovation for Environmental & Water Technology Singapore
- NUS-Environmental Research Institute Singapore
- Pôle EAU France
- Queensland Government Australia
- Sandia National Laboratories USA
- Singapore Centre on Environmental Life Sciences Engineering Singapore
- Singapore Membrane Technology Centre Singapore
- Singapore Polytechnic Singapore
- Singapore University of Technology and Design Singapore
- Singapore Water Association Singapore
- Singapore-MIT Alliance for Research and Technology Singapore
- Singapore-Peking-Oxford Research Enterprise for Water Eco-Efficiency Singapore
- Stanford University USA
- Stowa Foundation for Applied Water Research Netherlands
- SWELIA Association France
- The Commonwealth Scientific and Industrial Research Organisation Australia
- Toray Singapore Water Research Center Singapore
- Toshiba Aqua Research Centre Singapore
- Trent University Canada
- Tropical Marine Science Institute Singapore
- Tsinghua University China
- UK Water Industry Research UK
- United States Environmental Protection Agency USA
- University of Canterbury New Zealand
- University of Illinois at Urbana-Champaign USA
- University of Maryland USA
- University of New South Wales Australia
- University of North Carolina USA
- University of Oxford UK
- University of Queensland Australia
- University of Waterloo Canada
- University of Western Australia Australia
- University of Toronto Canada
- Water Environment Research Foundation USA
- Water Research Commission South Africa
- Water Research Foundation USA
- Water Services Association of Australia Australia
- WaterReuse Research Foundation USA
- World Health Organization Switzerland

Water utilities and companies

- Affordable Water New Zealand
- Aqleo Singapore
- Aquaporin A/S Denmark
- Amiad Filtration Systems Israel
- Anaergia Canada
- Aromatrix Technologies Hong Kong
- Asahi Kasei Corporation Japan
- Awa Instruments Singapore
- BASF SE Germany
- Baleen Filters Australia
- Becton, Dickinson and Company USA
- Biofuel Research Singapore
- Black & Veatch Corporation USA
- Blueleg Monitor Netherlands
- Blue I Water Technologies Israel
- Boerger Pumps Asia Singapore
- Boustead Salcon Water Solutions Singapore
- Camp Dresser & Mckee USA
- Ceraflo Singapore
- CH2M USA
- CPG Corporation Singapore
- Daily Life Renewable Energy Singapore
- Darco Water Technologies Singapore
- DHI Water & Environment Singapore
- Dow Chemical Company USA
- Dragon Water Group Germany
- DSO National Laboratories Singapore
- D-RON Singapore Singapore
- ecoWise Technologists & Engineers Singapore
- Endress+Hauser Instruments International Switzerland
- Envipure Singapore
- Enviro Pro Green Innovation Singapore
- Envirotech and Consultancy Singapore
- Evoqua Water Technologies USA
- ExxonMobil Asia Pacific Singapore
- Fluigen Singapore
- GE Water & Process Technologies USA
- GlobalFoundries USA
- Global Water Intelligence UK
- Glowtec Environmental Group Singapore
- GMF-Gouda Singapore Netherlands
- GrahamTek Nuwater Singapore
- Grundfos Denmark
- HACH USA
- Hitachi Japan
- Huber Technology Germany
- Hydrovision Asia Singapore
- Hyflux Singapore
- Institute of Occupational Medicine Singapore Singapore
- Integrated Land Management USA
- iWOW Connections Singapore
- Joyce River Hi-Tech Technologies Singapore
- Johnson Pacific Singapore
- Kemira Finland
- Keppel Seghers Singapore
- Kinrot Holdings Israel
- Koch Membrane System USA
- Kupps & Sachs Singapore
- Kuraray Japan
- Kurita Water Industries Singapore
- K-One Industries Singapore
- Lighthouse Integral Singapore
- Liqtch USA
- Mann+Hummel Ultra-Flo Singapore
- Mattenplant Singapore
- Meiden Singapore Singapore
- Mekorot Israel
- Membrane Instruments and Technology Singapore
- Memstar Technology Singapore
- Metawater Japan
- Mitsubishi Japan
- Moya Dayen Singapore
- MWH Asia Pacific Australia
- Natflow Singapore
- Nitto Denko Corporation Japan
- Optiqua Technologies Singapore
- Orange County Water District USA
- PulverDryer Technologies USA
- PWN Technologies Netherlands
- Rand Water South Africa
- Rehau Unlimited Polymer Solutions Germany
- Saline Water Conversion Corporation Saudi Arabia
- Sembcorp Industries Singapore
- SUEZ France
- Tritech Engineering and Testing (Singapore) Pte. Ltd. Singapore
- Trojan Technologies Canada
- United Engineers Singapore
- United Envirotech Singapore
- Veolia Environment France
- Visenti Singapore
- Vitens Netherlands
- Water And Sewerage Authority Trinidad & Tobago
- Water Optics Technology Singapore
- WH2O Technology Singapore
- Wisewater Singapore
- Xylem USA
- ZWEEC Analytics Singapore



For more information, visit www.pub.gov.sg