

CODE OF PRACTICE
ON
SURFACE WATER DRAINAGE



Water for All: Conserve, Value, Enjoy

Sixth Edition - Dec 2011
with amendments under
Addendum No. 1 – Jun 2013

CODE OF PRACTICE
ON
SURFACE WATER DRAINAGE
(Sixth Edition - Dec 2011)

Addendum No. 1 - June 2013

This addendum shall be read in conjunction with the Code of Practice on Surface Water Drainage (Sixth Edition - Dec 2011) and shall form part of the Code of Practice.

S/No.	Part /Page No	Amendments /corrections
1	XII	Add new point “2.4 Flood Protection Measures”
2	XIII	Add new point “8.1 Integration of Adjacent Watercourses with Developments”
3	XIII	Add new point “8.2 Integration of ABC Waters Design Features within Developments”
4	XIV	Replace Clause “Flood Protection Measures (i.e. Crest/ Flood barriers/ Pumped drainage system)” <i>with</i> “Submissions on Storm Water Drainage System (including Crest/Flood barriers/Pumped drainage system/ABC Waters design features)” <i>in</i> Clause 13.2.
5	XV	Replace “Appendix 2 Rainfall Intensity-Duration-Frequency Curves for Singapore Island” <i>with</i> “Appendix 2 Submission Requirements for Flood Protection Measures”
6	XV	Replace Appendix 4 <i>with</i> “Rainfall Intensity- Duration- Frequency Curves for Singapore Island”
7	XV	Add new Appendix “Appendix 5 Submission Requirements for “As Constructed” Drainage Drawings”
8	XV	Replace Drawing 5 <i>with</i> “Enhanced Drop-Inlet Chambers”
9	XV	Replace Drawing 8 <i>with</i> “Earth Control Measures at Construction Site”
10	XV	Replace Drawing 9 <i>with</i> “Slot-outlets and Access Shaft”
11	-	Delete Drawing No 10 “Frame for Pedestrian Grating”
12	-	Delete Drawing No 11 “Vehicular Grating and Access Shaft”
13	-	Delete Drawing No 12 “Frame for Vehicular Grating”
14	-	Delete Drawing No 13 “Earth Control Measures at Construction Site”
15	2	Replace “Central Building Plan Unit” <i>with</i> “Central Building Plan Department (CBPD) refers to the Central Building Plan Department of National Environment Agency (NEA).”

16	7	<p>Replace Clause “2.1.1c” <i>with</i> “Special Facilities and Developments with linkages to Special Underground Facilities</p> <p>For special facilities including Rapid Transit stations, airport runways and wafer fabrication plants, and all developments with direct or indirect links to special underground facilities such as underground Rapid Transit stations, the minimum platform level shall not be lower than:-</p> <ul style="list-style-type: none"> • 104.0 mRL for developments along the southern coast, and • 104.5 mRL for developments along the northern coast; or • 1 m above the adjacent road/ground level; or • 1 m above the highest recorded flood level, if any, as advised by the Board; or • Any other level as may be specified by the Board; <p>whichever is the highest.”</p>
17	7	<p>Replace “Flood Protection Measures” <i>with</i> “Exception cases” in Clause 2.1.2</p>
18	7	<p>Replace Clause “2.1.2b” <i>with</i> “Flood protection measures must be included in the design to provide at least the same level of flood protection that the minimum platform and/or crest levels would provide for the building. Details of proposed flood protection measures should be submitted to the Board for approval. Implementation of the flood protection measures shall comply with the requirements stipulated in Section 2.4.</p> <p>Notwithstanding the above, the Qualified Person shall advise the developer/owner to raise the platform level and/or crest level to the highest possible levels before considering the deployment of flood protection measures. In addition, the developer/owner shall be advised that the development site may be subject to flood risks despite the implementation of flood protection measures.”</p>
19	8	<p>Replace Clause “2.1.3bi” <i>with</i> “addition & alteration (A&A) works to an existing building where there are no linkages to special underground facilities;”</p>
20	8	<p>Replace Clause “2.1.3bii” <i>with</i> “partial reconstruction works to an existing building involving only the building of additional floors without reconstruction of the first storey and where there are no linkages to special underground facilities;”</p>
21	8	<p>Replace after Clause “2.1.3bv” <i>with</i> “For these development proposals, the Qualified Person shall advise the developer/owner that the minimum platform levels are still recommended as a protection measure to reduce flood risks. If lower platform levels are adopted, the developer/owner shall be advised that the development site may be subject to flood risks and to install flood barriers as stipulated in Section 2.4 where possible.”</p>
22	9	<p>Replace Clause 2.2c “Section 2.2b” <i>with</i> “Clause 2.2b”</p>

23	10	<p>Insert new Clause after Clause “2.3” <i>with</i> “2.4 Flood Protection Measures</p> <p>Flood protection measures as stipulated under Clauses 2.1.2(b) and 2.1.3(b) will be subjected to the following requirements, including those stipulated in Appendix 2:</p> <p>(a) <u>General Development</u> Flood barriers shall be installed at all points of entry and exit for the building premises (at ground/platform level).</p> <p>(b) <u>Commercial/ Multi-Unit Residential Developments with Basements and Special Facilities and Developments with linkages to Special Underground Facilities</u> Flood barriers shall be installed at: i) all points of entry and exit for the building premises (at ground/platform level); or ii) all points of entry and exit for the entire development area.</p> <p>(c) The developer/owner shall obtain the necessary clearance from relevant authorities to install the flood protection measures during the Development Control (DC) stage for approval.</p> <p>(d) Details of the flood protection measures and Standard Operating Procedure (SOP) should be submitted to the Board during Building Plan (BP) stage for record.”</p>
24	12	Replace Clause 4.4.3 “Section 4.9” <i>with</i> “Clause 4.9.1”
25	20	Replace Clause 6.3.5 “Drawing No 13” <i>with</i> “Drawing No 8”
26	21	Replace Clause 6.3.8Ba “a solid kerb of at least 600mm high should” <i>with</i> “a boundary wall of at least 600mm high shall”
27	26	Replace “Appendix 2” <i>with</i> “Appendix 4”
28	26	<p>Insert new Clause after Clause “7.1.4” <i>with</i> “7.1.5 Maximum Allowable Peak Runoff</p> <p>Industrial, commercial, institutional and residential developments greater than or equal to 0.2 hectares in size are required to control the peak runoff discharged from the development sites. The maximum allowable peak runoff to be discharged to the public drains will be calculated based on a runoff coefficient of 0.55, and for design storms with a return period of 10 years and for various storm durations of up to 4 hours (inclusive). Peak runoff reduction can be achieved through the implementation of ABC Waters design features and structural detention and retention features, such as:</p> <p>a) Detention tanks; b) Retention/sedimentation ponds; c) Wetlands; d) Green roofs; e) Planter boxes; f) Bioretention swales; g) Porous pavements; h) Bioretention basins or rain gardens, etc.</p> <p>The QP shall be required to submit details (calculations and/or hydraulic model results) showing how the proposed system meets the required peak runoff rates. Due consideration shall be given to meeting ABC Waters stormwater quality objectives, which will often require treatment of stormwater runoff using ABC Waters design features. For design guidance on the ABC Waters design features, QPs can refer to the ABC Waters Guidelines and relevant chapters in the Engineering Procedures, available on the PUB website.”</p>

29	29	Replace Chapter “8” <i>with</i> “Integration of Adjacent Watercourses with Developments and ABC Waters Design Features within Developments”
30	29	Replace Clause “8.1” <i>with</i> “8.1 Integration of Adjacent Watercourses with Developments”
31	29	<p>Insert new Clause after Clause “8.1” <i>with</i> “8.1.1 As part of the Active, Beautiful, Clean Waters (ABC Waters) Programme, integration of adjacent watercourses with proposed developments is encouraged, whilst satisfying the engineering requirements for drainage functions without posing any public safety, maintenance or environmental problems. These include, but are not limited to:</p> <ul style="list-style-type: none"> (a) Enhancing the accessibility or connectivity to waterbodies/waterways, eg. creating community spaces for adjacent to watercourses and providing boardwalks to bring people closer to water, etc.; (b) Providing aesthetic treatment to waterways, eg. use of a more natural finish such as block pitching or imprints on canal walls, planting along the canal walls, etc.; (c) Installing ABC Waters Design features to detain and treat storm water runoff closer to the source (see Section 8.2 for further details).”
32	29	Replace Clause “8.2” <i>with</i> “8.2 Integration of ABC Waters Design Features within Developments”
33	29	<p>Insert new Clause after Clause “8.2” <i>with</i> “8.2.1 Qualified Persons together with the developer/ owner can significantly enhance the development by incorporating into their designs appropriate ABC Waters Design features as described in the latest version of “ABC Waters Design Guidelines” and “Engineering Procedures for ABC Waters design features” published by the Board (available at http://www.pub.gov.sg/abcwaters). These guidelines were developed based on the following principles:-</p> <ul style="list-style-type: none"> (a) Reduction of runoff and peak flow from the development site by implementing local ABC Waters design features that provide detention measures and minimise impervious areas; (b) Improvement of quality of water draining from the development into receiving environment. For example, through effective filtration and retention measures via ABC Waters design features, runoff from the site can be treated to remove pollutants and silt, thereby protecting the water quality in waterways downstream; (c) Integration of stormwater treatment into the landscape by incorporating multiple-use ABC Waters design features that also maximise the aesthetics and recreational amenities of developments; and (d) Protection and enhancement of natural water systems within the development site.”
34	30	Insert new Clause after Clause “8.2” <i>with</i> “8.2.2 The developer/owner shall engage an ABC Waters (Active, Beautiful, Clean Waters) Professional to design, oversee the construction of, and develop a maintenance plan for the ABC Waters design features. The developer/owner shall submit the concept design and design calculations, endorsed by the ABC Waters Professional, to the Board as part of DC submission.”
35	30	Insert new Clause after Clause “8.2.1” <i>with</i> “8.2.3 For ABC Waters design features that are designed to be part of the measures to comply with Clause 7.1.5, the developer/owner shall maintain the ABC Waters design features regularly to ensure that these features are well maintained and remain effective in serving the functions as stipulated in Clause 7.1.5. The developer/owner shall comply with the submission of documents as stipulated in Section 13.2.”
36	29	Clause “8.3” rename as Clause “8.1.2”

37	29	Clause “8.4” rename as Clause “8.1.3”
38	32	<p>Replace Clause “9.8.1” <i>with</i> “Runoff from road carriageways and carparks shall be effectively drained away to prevent water stagnation and to ensure road safety. Drop-inlet chambers and concealed scupper drainage shall be designed in accordance with the Land Transport Authority's standard specifications and shall be provided at maximum 6 m spacings along all road carriageways.</p> <p>For flood prone areas, hotspots or any other areas as specified by the Board, enhanced drop-inlet chambers (shown in Drawing No. 5) shall be provided.”</p>
39	32	Replace Clause 9.8.2 “Drawing No. 5” <i>with</i> “Drawing No. 9”
40	32	Replace Clause “9.12.1” <i>with</i> “All gratings provided over closed drains/culverts shall be hinged to fixed frames securely embedded into the drain structures. Mild steel heavy duty gratings shall be used for closed drains subjected to vehicular loadings, whereas light duty gratings shall only be used for pedestrian loadings. Chequered plates shall be fixed on the pedestrian gratings for those closed drains narrower than 2 m (internal width). The gratings, frames and chequered plates shall be galvanised. The details of the gratings and chequered plates shall be designed in accordance with Land Transport Authority’s standard specifications.”
41	33	Replace “Clause 9.12.3 internal width of $600\text{ mm} \leq W \leq 750\text{ mm}$ “6 m (for drain $\leq 1\text{ m}$ deep) or 18 m (for drain $> 1\text{ m}$ deep)” <i>with</i> “6 m”
42	33	Replace Clause 9.12.4 “Drawing No. 11” <i>with</i> “Drawing No. 9”
43	33	<p>Replace Clause “9.13” <i>with</i> “Where an entrance culvert/crossing is proposed at a stretch of closed drain, gratings/openings shall be provided at the closed drain sections immediately upstream and downstream of the proposed entrance culvert/crossing.</p> <p>Under the exceptional circumstance where the entrance culvert/crossing is shallower than 600 mm, hinged open gratings shall be installed throughout the whole length of the entrance culvert/crossing.”</p>
44	38	<p>Replace Clause “11.1” <i>with</i> “QPs are required to declare that their platform and crest levels are in compliance with the Code of Practice on Surface Water Drainage and constructed according to approved plans when applying for Temporary Occupation Permit (TOP) clearance.</p> <p>The declaration shall consist of the application for TOP clearance and be supported by as-built survey plans indicating the crest levels, platform levels and flood protection levels (based on the approved flood protection measures), where applicable, and any other relevant information as required by the Board, prepared and endorsed by a Registered Surveyor. The Board will only issue TOP clearance through CBPD to the developer/owner when the declaration and all necessary supporting documents are submitted and assessed to be in compliance with the requirements of approved plans and the Code of Practice on Surface Water Drainage.”</p>
45	39	Replace Clause 12.4 “Appendix 4” <i>with</i> “Appendix 5”
46	41	Replace Clause “13.2” <i>with</i> “Submissions on Storm Water Drainage System (including Crest/Flood barriers/Pumped drainage system/ABC Waters design features)”

47	41	<p>Insert new Clause after Clause “13.2” <i>with</i> “13.2.1 Crest Level(s)</p> <p>(i) For Commercial/ Multi-Unit Residential Developments with Basements (e.g. shopping malls, large office buildings and condominiums), the developer/owner shall, every three years upon obtaining the Temporary Occupation Permit (TOP), declare that the crest levels are in compliance with the Code of Practice on Surface Water Drainage and constructed according to approved plans. When there is deviation from approved plans, the declaration shall be supported by as-built survey plans indicating the crest levels, platform levels, adjacent road levels, and any other relevant information as required by the Board, prepared and endorsed by a Registered Surveyor.</p> <p>When requested by the Board, this declaration shall be submitted annually upon obtaining the Temporary Occupation Permit (TOP).</p> <p>(ii) For Special Underground Facilities and Developments with linkages to Special Underground Facilities, the developer/owner shall declare that the crest levels are in compliance with the Code of Practice on Surface Water Drainage and constructed according to approved plans annually upon obtaining the Temporary Occupation Permit (TOP). This declaration shall be prepared and endorsed by a Registered Surveyor.”</p>
48	41	<p>Insert new Clause after Clause “13.2.1” <i>with</i> “13.2.2 Flood Barriers/Detention Tanks/ABC Waters Design Features/Pumped Drainage System</p> <p>The developer/owner, when requested by the Board, shall submit the following documents (where applicable) annually upon obtaining the Temporary Occupation Permit (TOP):</p> <p>(i) Certificate of inspection on flood barriers on-site including leak test complying with relevant international standards or any requirements specified by the Board and endorsed by a Civil/Mechanical Qualified Person (where applicable);</p> <p>(ii) Amendments to the standard operating procedure (SOP) of the flood barrier endorsed by a Civil and/or Mechanical Qualified Person;</p> <p>(iii) Certificate of inspection on the pumped drainage system (for the basement and/or detention tank) endorsed by a Mechanical or Electrical Qualified Person;</p> <p>(iv) Records on the Operational Performance of Flood Protection Measures/Pumped Drainage Systems prior to the onset of the North East Monsoon season (Nov – Jan); and</p> <p>(v) Certificate of inspection on ABC Waters design features endorsed by an ABC Waters Professional. The certificate of inspection shall contain a declaration that the features have been inspected, and are maintained satisfactorily and functioning well.”</p>

49	43	<p>Replace Appendix” 2” with “APPENDIX 2: SUBMISSION REQUIREMENTS FOR FLOOD PROTECTION MEASURES</p> <ol style="list-style-type: none"> 1) <u>During Development Control (DC) stage</u> For all developments with flood protection measures, the following documents, endorsed by a Qualified Person, shall be submitted: <ol style="list-style-type: none"> (i) Proposed plans indicating the crest levels and/or platform levels with and without flood barrier at various entrance and exit points; 2) <u>During Building Plan (BP) stage</u> For developments where flood barriers are automated and/or with more than 2 points of entry/exit, or when requested by the Board, the following shall be submitted: <ol style="list-style-type: none"> (i) Details on the size, type and design of the flood barrier. (ii) Details on the standard operating procedure (SOP) including the proposed maintenance plan of the flood barrier to be endorsed by a Civil and/or Mechanical Qualified Person, and the developer owner. 3) <u>During Temporary Occupation Period (TOP) stage</u> For all developments with flood protection measures, the following documents, endorsed by a Registered Surveyor, shall be submitted together with the declaration that their platform and crest levels are in compliance with the Code of Practice on Surface Water Drainage and constructed according to approved plans: <ol style="list-style-type: none"> (i) As-built survey plans indicating the crest levels, platform levels and the flood protection levels (based on the approved flood protection measures). 4) <u>Certificate of Statutory Completion (CSC) stage</u> For developments where automated flood barriers are implemented, the following documents, endorsed by a Qualified Person (Civil and/or Mechanical), shall be submitted: <ol style="list-style-type: none"> (i) Leak Test Certification on the installed flood barrier, in compliance with relevant international standards or any requirements specified by the Board. 5) <u>Maintaining the Integrity of the Storm Water Drainage System including Flood Protection Measures</u> The developer/owner of premises with flood protection measures, when requested by the Board, shall comply with the submission of documents upon obtaining the Temporary Occupation Permit (TOP) as stipulated in Section 13.2.”
50	46	Replace “Appendix 2” with “Appendix 4”
51	47	Replace “Appendix 4” with “Appendix 5”

54	57	<p>Replace Drawing No 9 “Slot-outlets and Access Shaft”</p> <p>This drawing shows schematically the drainage facilities and minimum structural requirements. Details of the structural, geotechnical and foundation systems are to be designed by Qualified Persons.</p> <p>Notes:</p> <ol style="list-style-type: none"> 1. ALL DIMENSIONS ARE IN MILLIMETRES UNLESS OTHERWISE STATED. 2. ALL CONCRETE TO BE MINIMUM GRADE UNLESS OTHERWISE STATED. 3. THE STRUCTURAL DETAILS OF THE REINFORCED CONCRETE PAVEMENT SHALL BE DESIGNED TO WITHSTAND PEDESTRIAN LOADINGS IN ACCORDANCE WITH LAND TRANSPORT AUTHORITY'S REQUIREMENTS. 4. SLOT-OUTLETS ARE TO BE PROVIDED FOR A MINIMUM DISTANCE OF 3 TIMES THE SIDE CARRIAGEWAY WIDTH OVER THE TRAILING EDGE OF THE T-JUNCTION WHERE THE T-JUNCTION IS LOCATED AT A LOWER LEVEL THAN THE CONNECTING SIDE CARRIAGEWAY AT INTERSECTIONS. DROP INLET CHAMBERS ARE TO BE PROVIDED AT INTERVALS OF 8.0m OVER A MINIMUM DISTANCE OF 3 TIMES THE SIDE CARRIAGEWAY WIDTH. <p>DRAWING NO. 9 SLOT-OUTLETS AND ACCESS SHAFT</p>
55	-	Delete Drawing No 10 “Frame for Pedestrian Grating”
56	-	Delete Drawing No 11 “Vehicular Grating and Access Shaft”
56	-	Delete Drawing No 12 “Frame for Vehicular Grating”
57	-	Delete Drawing No 13 “Earth Control Measures at Construction Site”

CODE OF PRACTICE
ON
SURFACE WATER DRAINAGE

Public Utilities Board would like to thank the following Professional Institutions for their invaluable advice and comments on the Code of Practice on Surface Water Drainage (Sixth Edition):

Association of Consulting Engineers, Singapore (ACES)

The Institution of Engineers, Singapore (IES)

Singapore Institute of Architects (SIA)

Public Utilities Board would also like to thank the Inter-Agency Drainage Review Committee (IADRC) which was formed in August 2010 to review the drainage design parameters in the Code of Practice on Surface Water Drainage. The committee was chaired by Public Utilities Board and comprised members from:

Building and Construction Authority (BCA)

Housing & Development Board (HDB)

Jurong Town Corporation (JTC)

Land Transport Authority (LTA)

National Environment Agency (NEA)

National Parks Board (NParks)

Singapore Land Authority (SLA)

Urban Redevelopment Authority (URA)

CONTENTS	Page
Introduction	1
Terminology	2-3
PART I PLANNING REQUIREMENTS	
1 Drainage Reserve	
1.1 Drainage Reserve Requirements	5
1.2 Vesting of Drainage Reserve for Development Proposal	5
1.3 Realignment of Drainage Reserve	5
1.4 Use of Drainage Reserve	5-6
2 Platform, Crest and Reclamation Levels	
2.1 Minimum Platform Level	6-8
2.2 Crest Level	9
2.3 Land Reclamation Level	9
2.4 Flood Protection Measures	10
3 Flood Protection of Underground Rapid Transit System	
3.1 Principles and Standards of Protection	11
3.2 Linkages to Underground Rapid Transit System	11
4 Drainage Planning Requirements	
4.1 Drains not to be Interfered with	12
4.2 Drainage Affecting Other Premises	12
4.3 Closed Drainage System	12
4.4 Internal Drainage System	12
4.5 Common Drain	13
4.6 Improvements to Existing Drain	13
4.7 Structure Over Roadside Drain/Outlet Drain	13
4.8 Hydraulic & Structural Calculations	13
4.9 Drainage for Terraced Developments	14
4.10 Drainage for Underground Facilities	14
4.11 Drainage at Reclaimed Land	15
4.12 Outfall Structure for Drain Connecting into Sea	15
5 Structures Within or Adjacent to Drain/Drainage Reserve	
5.1 No Structure within Drain/Drainage Reserve	16
5.2 Drain Connection within Drainage Reserve	16
5.3 Embankments and Structures adjacent to Drain/Drainage Reserve	16
5.4 Structure Within/Across Drain/ Drainage Reserve	17-18
5.5 Services Within Drain/Drainage Reserve	18

6	Requirements for Construction Activities	
6.1	General Requirements	19
6.2	Laying and Diversion of Services	20
6.3	Earth Control Measures	20-22
6.4	Earthworks	23
6.5	Roadworks	23
6.6	Reclamation Works	23
PART II	DESIGN REQUIREMENTS	
7	Drainage Design and Considerations	
7.1	Computation of Peak Runoff	25-27
7.2	Computation of Discharge Capacity	27
7.3	Design Considerations	28
8	Aesthetic Treatment of Watercourses and Integration of Adjacent Watercourses with Developments	
8.1	Integration of Adjacent Watercourses within Developments	29
8.2	Integration of ABC Waters Design Features within Developments	29-30
9	Drainage Structures and Facilities	
9.1	Drain and Culvert	31
9.2	Roadside Drain	31
9.3	Transition	31
9.4	Curve and Bend	31
9.5	Sump for Drain Intersections	31
9.6	Maintenance Access for Drainage Reserve	31-32
9.7	Markers along Edge of Drainage Reserve	32
9.8	Drop-inlet Chamber and Slot-outlet	32
9.9	Safety Railings	32
9.10	Special Railings for Park Connectors	32
9.11	Rungs in Drains	32
9.12	Grating over Closed Drain/Culvert	32-33
9.13	Entrance Culvert/Crossing	33
9.14	Live Loads on Drains	34
10	Pumped Drainage System	35-36

Appendices

Appendix 1	Drainage Reserve Requirements
Appendix 2	Submission Requirements for Flood Protection Measures
Appendix 3	Principles and Standards for Flood Protection of Underground Rapid Transit System
Appendix 4	Rainfall Intensity- Duration- Frequency Curves for Singapore Island
Appendix 5	Submission Requirements for “As Constructed” Drainage Drawings

Drainage Standard Drawings

Drawing No. 1	U-shaped & Trapezoidal Drains and Box Culvert
Drawing No. 2	Standard Roadside Drains
Drawing No. 3	Maintenance Access for Drainage Reserves
Drawing No. 4	Drainage Reserve Marker, Bollard and Posts & Chains
Drawing No. 5	Enhanced Drop Inlet-Chambers
Drawing No. 6	Standard Safety Railings
Drawing Nos. 7A & 7B	Approved Special Railings
Drawing No. 8	Earth Control Measures at Construction Site
Drawing No. 9	Slot-outlets and Access Shaft

CODE OF PRACTICE
ON
SURFACE WATER DRAINAGE

INTRODUCTION

Singapore is situated close to the equator and is subjected to heavy tropical rainstorms. The average annual rainfall in Singapore is about 2,400 mm. There are no distinct wet or dry seasons as rain falls every month of the year. The two main seasons, the North-east monsoon season (from late November to March) and the South-west monsoon season (from late May to September) refer to the prevailing winds dominant at the time of the year. The transitional months (or Inter-monsoon period) separating the two monsoons are April to early May, and October to early November.

The total land area of Singapore is approximately 712.4 km² (as at 2010). This area comprises the mainland and other islands. The mainland measures 49 km from east to west and 25 km from north to south with a coastline of 189 km. The topography of the main island of Singapore is undulating with its highest point, the Bukit Timah Peak at only 163 m above mean sea level. Much of Singapore lies within 15 m of mean sea level and the ground levels of some 30% of Singapore are less than 5 m above mean sea level.

This Code of Practice on Surface Water Drainage is issued under Section 32 of the Sewerage and Drainage Act (Chapter 294). It specifies the minimum engineering requirements for surface water drainage for new developments. The Qualified Persons shall ensure that all aspects of surface water drainage are effectively taken care of in their planning, design and implementation of the development proposals.

Public Utilities Board
Singapore

TERMINOLOGY

“ABC Waters Design features”	are environmental friendly features that detain and treat stormwater runoff using natural elements like plants and soil filter media. The features also enhance the surroundings with biodiversity and aesthetic value;
"Architect"	means a person who is registered under the Architects Act 1991 and has in force a practising certificate issued under that Act;
"Board"	means the Public Utilities Board reconstituted under Section 3 of the Public Utilities Act 2001 (Act 8 of 2001);
“Catchment”	means the area which drains into a storm water drainage system;
"Central Building Plan Department"(CBPD)	refers to the Central Building Plan Department of National Environment Agency (NEA);
"Commercial/Multi Unit Residential Developments with Basements”	Refers to developments with basements such as shopping malls, large office buildings, condominiums, hotels and hospitals;
"Common Drain"	refers to a drain of less than 1.0 m wide serving more than one premises and without drainage reserve;
"Crest Level"	means the bottom level of any openings (including ventilation and services openings) or summit level of a ramp or accessway leading into or away from an underground or basement structure or facility, including the summit level of any exits from the underground facilities;
"Drain"	includes any canal, culvert, conduit, river or watercourse;
"Drainage Reserve"	means any land set aside for drainage works pursuant to development proposals approved by a competent authority;
"Drainage Works"	includes any engineering works for the construction, alteration and maintenance of any storm water drainage system;
"General Developments"	refers to developments other than Commercial/ Multi-Unit Residential Developments with Basements and Special Facilities;
"Internal Drain"	refers to a drain within the premises;
"Outlet Drain"	refers to a drain within a Drainage Reserve;
"Platform Level"	means the general ground level of a proposed development;
"Professional Engineer"	means a person who is registered under the Professional Engineers Act 1991 and has in force a practising certificate issued under that Act;

"Qualified Person" (QP) means a person who is an Architect or a Professional Engineer or a suitably qualified person registered under other relevant legislation;

"Qualified Erosion Control Professional" (QECF) means a Professional Engineer who is registered under the Professional Engineers Act Chapter 253, has in force a practising certificate issued under that Act, and has satisfactorily completed a specialized professional course in erosion and sediment control;

"Reclamation Level" means the filled level of a reclamation site;

"Roadside Drain" refers to a drain within the land set aside for drainage in a Road Reserve;

"Storm Water Drainage System" means a system of drains for the conveyance or storage of storm water and includes

- (a) any weir, grating, float boom, gauge, tidegate, sump, storage pond, pumping station, maintenance access and debris interception and removal facility related to such system;
- (b) any structure constructed to convey, store or measure storm water or for flood alleviation; and
- (c) any bridge over or railing for any such drain or any appurtenance thereof;

CODE OF PRACTICE ON SURFACE WATER DRAINAGE

PART I

PLANNING REQUIREMENTS

- 1 Drainage Reserve
- 2 Platform, Crest and Reclamation Levels
- 3 Flood Protection of Underground Rapid Transit System
- 4 Drainage Planning Requirements
- 5 Structures Within or Adjacent to Drain/Drainage Reserve
- 6 Requirements for Construction Activities

CODE OF PRACTICE ON SURFACE WATER DRAINAGE

PART I

PLANNING REQUIREMENTS

1 DRAINAGE RESERVE

1.1 Drainage Reserve Requirements

The width of a Drainage Reserve is based on the required drain size as determined by the Board. Requirements for Drainage Reserves are shown in Appendix 1.

1.2 Vesting of Drainage Reserve for Development Proposal

1.2.1 Any land which has been set aside as Drainage Reserve pursuant to any development proposal shall be vested gratis in the Government, free of all encumbrances, as and when required by the Board.

1.2.2 The Drainage Reserve shall be delineated as a separate lot with a separate plot number in the layout plans.

1.3 Realignment of Drainage Reserve

A Drainage Reserve may be realigned subject to the following conditions:-

- (a) the proposed drain diversion is technically and physically feasible and acceptable to the Board; and
- (b) the developer/owner shall construct the proposed drain to the size as determined by the Board.

1.4 Use of Drainage Reserve

1.4.1 Under special circumstances, the developer/owner may be allowed the use of the Drainage Reserve subject to the following conditions:-

- (a) the developer/owner shall allow the Board or the Board's agent access to carry out drainage works within the Drainage Reserve as and when necessary.
- (b) the developer/owner shall not construct any structures or facilities on, over or under the Drainage Reserve.
- (c) the developer/owner shall be responsible for the physical maintenance of the land within the Drainage Reserve.
- (d) the developer/owner shall be responsible for the structural maintenance of the storm water drainage system within the Drainage Reserve.
- (e) the developer/owner shall be responsible for public safety within the Drainage Reserve.

- (f) the developer/owner shall at all times indemnify and keep indemnified the Government fully and completely against all liabilities of whatsoever nature and description which may be incurred or suffered by the Government in connection with or arising out of the use of the Drainage Reserve by the developer/owner and against all actions, proceedings, claims, costs and expenses therefrom.
- (g) Any additional conditions deemed necessary by the Board.

2 PLATFORM, CREST AND RECLAMATION LEVELS

2.1 Minimum Platform Level

The minimum platform level of a development site as specified by the Board is the required minimum ground level of that proposed development. The platform levels as determined shall be indicated on the layout plans.

The minimum platform level required for a proposed development depends on its locality and the type of development, as categorised below:-

2.1.1 Type of Development

(a) General Developments

The minimum platform level shall not be lower than:-

- (i) 104.0 mRL for developments along the southern coast, and 104.5 mRL for developments along the northern coast; or
- (ii) 300 mm above the adjacent road/ground level; or
- (iii) 600 mm above the highest recorded flood level, if any, as advised by the Board; or
- (iv) Any other level as may be specified by the Board;

whichever is the highest.

(b) Commercial/ Multi-Unit Residential Developments with Basements (e.g. shopping malls, large office buildings and condominiums)

The minimum platform level shall not be lower than:-

- (i) 104.0 mRL for developments along the southern coast, and 104.5 mRL for developments along the northern coast; or
- (ii) 600 mm above the adjacent road/ground level; or
- (iii) 600 mm above the highest recorded flood level, if any, as advised by the Board; or
- (iv) Any other level as may be specified by the Board;

whichever is the highest.

(c) **Special Facilities and Developments with linkages to Special Underground Facilities**

For special facilities, including Rapid Transit stations, airport runways and wafer fabrication plants, and all developments with direct or indirect links to special underground facilities such as underground Rapid Transit stations, the minimum platform level shall not be lower than:-

- (i) 104.0 mRL for developments along the southern coast, and 104.5 mRL for developments along the northern coast; or
- (ii) 1 m above the adjacent road/ground level; or
- (iii) 1 m above the highest recorded flood level, if any, as advised by the Board; or
- (iv) Any other level as may be specified by the Board;

whichever is the highest.

2.1.2 **Exception cases**

If, subject to approval of the Board, the minimum platform levels as specified in Clause 2.1.1 cannot be met, the following conditions (a) and (b) must be met:

- (a) The platform level of the building structure must be at least;
 - (i) 103.5 mRL for developments along the southern coast, and 104.0 mRL for developments along the northern coast; or
 - (ii) 300 mm above the adjacent road/ ground level; or
 - (iii) 300 mm above the highest recorded flood level, if any, as advised by the Board;

whichever is highest

and;

- (b) Flood protection measures must be included in the design to provide at least the same level of flood protection that the minimum platform and/or crest levels would provide for the building. Details of proposed flood protection measures should be submitted to the Board for approval. Implementation of the flood protection measures shall comply with the requirements stipulated in Section 2.4.

Notwithstanding the above, the Qualified Person shall advise the developer/owner to raise the platform level and/or crest level to the highest possible levels before considering the deployment of flood protection measures. In addition, the developer/owner shall be advised that the development site may be subject to flood risks despite the implementation of flood protection measures.

2.1.3 Compliance with Minimum Platform Levels

- (a) All new development proposals including reconstruction proposals shall comply with the requirements for minimum platform levels except those listed in item (b) below.
- (b) The following proposals need not comply with the required minimum platform levels:-
 - (i) addition & alteration (A&A) works to an existing building where there are no linkages to special underground facilities;
 - (ii) partial reconstruction works to an existing building involving only the building of additional floors without reconstruction of the first storey and where there are no linkages to special underground facilities;
 - (iii) conservation projects;
 - (iv) temporary development works intended for use for a temporary period;
 - (v) any other works as may be specified by the Board.

For these development proposals, the Qualified Person shall advise the developer/owner that the minimum platform levels are still recommended as a protection measure to reduce flood risks. If lower platform levels are adopted, the developer/owner shall be advised that the development site may be subject to flood risks and to install flood barriers as stipulated in Section 2.4 where possible.

2.1.4 Ancillary Areas

- (a) Where the minimum platform levels for developments in low-lying areas are significantly higher than the adjacent road/ground levels, the Qualified Person may apply in writing to Board for approval to construct the ancillary areas at below the minimum platform levels so as to tie-in with the adjacent low-lying road/ground levels or to satisfy other planning and environmental considerations.
- (b) The ancillary areas include:-
 - (i) entrance driveways;
 - (ii) bin centres;
 - (iii) turfed compound areas;
 - (iv) car porch for single unit development; and
 - (v) other areas as may be approved by the Board.

2.2 Crest Level

Minimum crest level is required for an entrance, exit or opening to a basement or underground structure (basement, tunnel, underground facility, etc) as follows:-

(a) Basements of General Developments

For basements, underpasses and sunken/underground facilities, the minimum crest level shall be at least 150 mm above the minimum platform level as specified in Clause 2.1.1(a).

(b) Special Underground Facilities and Basements of Commercial/ Multi-Unit Residential Developments

For Mass Rapid Transit underground stations/tunnels, underground road networks, depressed roads, basements of Commercial/ Multi-Unit Residential Developments and other special underground facilities, the minimum crest level shall be at least 300 mm above the minimum platform level as specified in Clause 2.1.1(b) & (c).

(c) Linkage to Special Underground Facilities and Basements of Commercial/ Multi-Unit Residential Developments

All developments with direct or indirect links to these special underground facilities and basements of Commercial/ Multi-Unit Residential Developments shall comply with the same minimum crest level requirements as specified in Clause 2.2(b).

2.3 Land Reclamation Level

For land reclamation works, the minimum reclamation level shall not be lower than:-

- (i) 104.0 mRL along the southern coast; and
- (ii) 104.5 mRL along the northern coast; or
- (iii) Any other levels as may be specified by the Board.

The platform levels required for any development subsequently carried out on the reclaimed land shall be higher than the reclamation level and shall be separately determined by the developer's Qualified Person to ensure effective internal drainage of the development site.

2.4 Flood Protection Measures

Flood protection measures as stipulated under Clauses 2.1.2(b) and 2.1.3(b) will be subjected to the following requirements, including those stipulated in Appendix 2:

(a) General Development

Flood barriers shall be installed at all points of entry and exit for the building premises (at ground/platform level).

(b) Commercial/ Multi-Unit Residential Developments with Basements and Special Facilities and Developments with linkages to Special Underground Facilities

Flood barriers shall be installed at:

- (i) all points of entry and exit for the building premises (at ground/ platform level); or
- (ii) all points of entry and exit for the entire development area.

(c) The developer/owner shall obtain the necessary clearance from relevant authorities to install the flood protection measures during the Development Control (DC) stage for approval.

(d) Details of the flood protection measures and Standard Operating Procedure (SOP) should be submitted to the Board during Building Plan (BP) stage for record.

3 FLOOD PROTECTION OF UNDERGROUND RAPID TRANSIT SYSTEM

3.1 Principles and Standards of Protection

Higher level of protection against flood risks is required for the Underground Rapid Transit System. The principles and standards of protection are outlined in Appendix 3.

3.2 Linkages to Underground Rapid Transit System

All developments with linkages to the Underground Rapid Transit System shall have the same protection requirements as for the Underground Rapid Transit System. All development proposals (including addition & alteration and reconstruction proposals) having such linkages shall be submitted to the Board for approval.

4 DRAINAGE PLANNING REQUIREMENTS

4.1 Drains not to be interfered with

No drain shall be interfered with or altered without the approval of the Board.

4.2 Drainage Affecting Other Premises

4.2.1 All runoff within a development site shall be discharged into a roadside drain or an outlet drain and not into the adjacent premises. A minimum 600 mm high solid boundary wall shall be erected around a development site to prevent surface runoff from overflowing into adjacent premises.

4.2.2 Where the runoff from the development site is discharged through an existing or proposed drainage outlet to the adjacent premises, the downstream drain at the adjacent premises must be able to cope with the runoff from the development site. The developer/owner may be required to upgrade the downstream drain to the required size as determined by the Board. The Qualified Person shall liaise with the downstream owner(s) before implementing the drainage proposal.

4.2.3 Where there is existing runoff flowing from adjacent premises or roads into or through the development site, the runoff shall continue to be allowed to discharge through the development site.

4.2.4 If a development site is sloping towards the adjacent premises, a drainage system shall be provided along the site boundary to prevent the runoff from discharging into adjacent premises.

4.3 Closed Drainage System

4.3.1 The internal width and clear depth of a roadside drain (including entrance culvert) shall be at least 600 mm.

4.3.2 The provision of gratings, openings and chequered plates for closed drains shall comply with Section 9.12.

4.3.3 Culverts Across Roads

4.3.3.1 Only box culverts shall be provided. The internal width and clear depth of a box culvert shall be at least 600 mm. For culverts across expressways and semi-expressways, the minimum size shall be 1.0 m x 1.0 m.

4.4 Internal Drainage System

4.4.1 The capacity of internal drains shall be sufficient to intercept and discharge all runoff from the development site.

4.4.2 The internal drains shall be designed for safety and ease of maintenance.

4.4.3 For drainage of the open backyard area of an intermediate terraced development, the internal conduit drain shall be laid in accordance with Clause 4.9.1.

4.4.4 Prior to discharging any storm water within the development site to public drain, vertical grating shall be installed at the outlet discharge point(s) of the internal drain located within the development site.

4.5 Common Drain

- 4.5.1 The internal width of a common drain shall be at least 450 mm.
- 4.5.2 Where reconstruction or extension of building/structure affects the existing common drain, the common drain shall be diverted outside of all building structures.
- 4.5.3 Where the existing common drain is located within the lot boundary but outside the existing boundary wall or fencing of the development site, the position of the existing boundary wall or fencing shall not be altered or realigned. The proposed location of new boundary wall or fencing shall be erected at the same position of the existing boundary wall or fencing. Any deviation to this arrangement shall be approved by the Board.

4.6 Improvements to Existing Drain

- 4.6.1 Pursuant to a development proposal, the developer/owner may be required to improve the existing drain such as the outlet drain flowing through the development site, the entrance culvert and the roadside drain.
- 4.6.2 The size (width and depth) and the alignment of the proposed drain shall be determined and approved by the Board.

4.7 Structure over Roadside Drain/Outlet Drain

- 4.7.1 No structure shall be constructed over the roadside drain or outlet drain without the approval of the Board. If approved, the drain under the structure shall be upgraded to the design requirements as determined by the Board.

4.8 Hydraulic & Structural Calculations

4.8.1 Hydraulic Calculations

For developments of area exceeding 0.4 hectare, the hydraulic calculations for internal drainage system (including the catchment plan), shall be endorsed by a Professional Engineer and submitted to the Board for record.

4.8.2 Structural Calculations

The structural calculations and plans for the following categories of drains shall be endorsed by a Professional Engineer and submitted to the Board for record:-

- (a) Drains within the Drainage Reserve; and
- (b) Closed roadside drains which do not follow the standard designs used by Land Transport Authority.

4.9 Drainage for Terraced Developments

4.9.1 Internal Conduit Drain

Where the open backyard area of each intermediate terraced development is not linked to the front yard by a corridor at ground level, a conduit drain for conveying surface runoff may run beneath the building itself. The conduit drain shall be at least 300 mm in diameter. The conduit drain shall be laid straight without any bend or sag in its alignment. At both the inlet and outlet ends of the conduit drain, maintenance sumps shall be provided with invert level drops of at least 150 mm deep. The conduit drain shall be fully supported along its entire length by (and not attached to) the ground beams of the building and shall form as part of the permanent structure of the building to ensure against settlement.

4.9.2 Common Backyard Drain

Where the internal drain of the proposed terraced housing development cannot be connected to the front roadside or outlet drain which is on higher ground, a common backyard drain running from lot to lot may be approved by the Board.

4.9.3 Drainage for Air Wells/Courtyards

Conduit drains serving the air wells or courtyards shall be designed to cater for the runoff and shall be at least 150 mm in diameter.

4.10 Drainage for Underground Facilities

4.10.1 Basements, tunnels and other underground facilities shall as far as possible be designed to prevent any ingress of storm water. Where ingress of storm water cannot be completely prevented, the catchment contributing to the ingress shall be kept to the minimum and an adequate pumped drainage system shall be provided. The minimum design and operation criteria for the pumped drainage system shall be as follows:-

- (a) A pump sump of sufficient size and adequate pumping facilities (as described in Part II) shall be provided.
- (b) The underground structure's catchment shall be totally segregated from the surface water catchment. This can be achieved by adopting, but not limited to the following design considerations:-
 - (i) Adequate crest protection levels at the entrances/ access points to underground structure shall be provided before discharging any surface runoff collected within the development to the public drain. Please refer to Section 2.2 on requirements on crest protection levels.
 - (ii) Channel runoff from the roofs, rainwater downpipes and all premises at and above ground level into surface gravity drains, but not into the underground structures.
 - (iii) Provide cut-off drains across the ramps or access ways to prevent surface water from entering underground structures. Cut-off drains serving the underground structure catchment must not be linked to the surface water drainage system.

4.10.2 Details of the design requirements of a pumped drainage system are described in Part II of this Code of Practice.

4.11 Drainage at Reclaimed Land

- (a) Proper drainage system, either temporary or permanent, shall be provided at all stages of reclamation works. All proposals of drainage works in connection with reclamation shall be submitted to the Board for approval.
- (b) Before the commencement of any reclamation works, drains affected by the reclamation shall be upgraded and extended to channel off the overland flows from the existing land upstream of the reclamation site.
- (c) All temporary drainage systems provided during the construction stage shall be cleansed and maintained regularly by the reclamation developer/owner to remove all obstructions, silt and rubbish until such time when the reclaimed land is developed and provided with a permanent drainage system.
- (d) The developer/owner shall maintain and manage the completed reclaimed land at all times to ensure that runoff is effectively drained away without causing drainage problems within the land or to the adjacent lots. The finished levels of the completed reclaimed land shall be formed in such a manner to ensure free surface water drainage and no localised ponding. All subsidence, low-lying areas and depressions shall be filled-up and graded to effect proper surface water drainage.

4.12 Outfall Structure for Drain Connecting into Sea

All outfall structures shall be extended under and beyond the sand bar area in an encased form and to discharge flow at below the low tide level. Where there is no sand bar formation along the shore, the outfall structure may be in an open or encased form subject to the approval of the Board. In all cases, the outfall shall extend adequately beyond the shoreline such that the sea-bed level is at least 500 mm below the outfall invert at the point of discharge. All outfall structures shall be protected against undermining and scouring effects. Clearance under Foreshores Act for the outfall structure is required.

5 STRUCTURES WITHIN OR ADJACENT TO DRAIN/DRAINAGE RESERVE

5.1 No Structure Within Drain/Drainage Reserve

No structure shall be constructed within a drain or Drainage Reserve.

5.2 Drain Connection Within Drainage Reserve

Drain connection within a Drainage Reserve shall be closed to maintain the continuity of access along the Drainage Reserve. The closed drain or the slab and its supporting structure/foundation shall be designed for heavy vehicular loading in accordance with Land Transport Authority's standards.

5.3 Embankments and Structures Adjacent to Drain/Drainage Reserve

All embankments and structures shall be set outside the Drainage Reserve. They shall be stable and independent of the drainage structures.

The design of embankments and structures near a drain or Drainage Reserve must not take into consideration the passive resistance offered by the existing or proposed drainage structures. The embankments and structures shall be stable when excavations up to 1.0 m below the invert or proposed invert of the adjacent drain are carried out. In addition, the Qualified Person shall ensure that the embankments and structures can be built without affecting the drainage structures.

5.3.1 Submission of Structural and Stability Calculations for Record

The structural and stability calculations for an embankment or a structure within 2 m from the edge of the Drainage Reserve shall be endorsed by a Professional Engineer and submitted to Board for record. The submission of such calculations shall not in any way absolve the Professional Engineer from his/her responsibility.

5.3.2 Drainage for Earth Retaining Structure

If an earth retaining structure is erected to raise the ground level of the development site above adjacent premises, runoff from the development site including the sub-soil flow from weepholes of the earth retaining structure shall be drained away by internal drains within the development site without overflowing into the adjacent premises.

If the earth retaining structure is erected to lower the ground level of the development site, the earth retaining structure shall not in any way obstruct existing sub-soil and overland flows discharging through the development site from the adjacent premises. The flows shall be drained off by internal drains within the development site.

5.4 Structure Within/Across Drain/Drainage Reserve

Where a structure is allowed to be located within a Drainage Reserve or drain by the Board, the following general technical requirements shall be complied with:

(a) Drainage Capacity

The affected drain must be hydraulically adequate as determined by the Board, otherwise it must be upgraded to the required size in conjunction with the proposal.

No structure shall be built within the flow channel. Where intermediate support is necessary to be provided within the channel for technical reasons, the reduced discharge capacity must be compensated by suitable enlargement of the channel. Such support, where approved, shall not be located at the centre of the channel or within the dry weather flow channel but at a suitable location where it will cause least obstruction to the flow.

(b) Structural Integrity

The Board may require the drain affected by the structures to be upgraded in conjunction with the proposal. The proposed structures to be erected within the drain or Drainage Reserve shall be designed and constructed to be independently supported.

All foundation structures/piers, in the vicinity of or within the drain or Drainage Reserve shall also be designed and constructed as independent structures from the drainage structures. These foundation structures/piers must be stable when excavations up to 1.0 m below the invert or proposed invert of the affected drain are carried out.

For a proposed structure to be constructed over a drain or Drainage Reserve, the vertical clearance between the base of the proposed structure and the cope of the existing or proposed drain shall be at least 100 mm.

The independent supports of a proposed structure must be located at least 300 mm away from the drainage structures.

(c) Maintenance

The proposed structure to be erected within the drain or Drainage Reserve shall not inhibit drainage maintenance work. The following provisions for maintenance shall be incorporated:-

- (i) For elevated structures (such as Rapid Transit or road viaduct, building, etc) over an outlet drain:

Sufficient headroom, viz minimum 5.4 m vertical clearance between the base of the proposed structure and the vehicular maintenance access within the Drainage Reserve, shall be provided.

- (ii) For at-grade structures (such as road deck, pedestrian mall, etc) over a length of outlet drain:

In addition to the provision, where appropriate, of gratings as specified in Section 9.12, access openings (4 m by 2 m) with 6 m wide lay-bys at about 500 m intervals shall be provided along but outside the road carriageway or mall; Additional requirements on the provision for maintenance may be specified by the Board.

(d) **Effective Drainage for Proposed Structure**

The proposed structure shall be provided with an effective drainage system to intercept and discharge the surface water runoff.

Where a slab is built over a roadside drain to provide access to premises, runoff from the slab shall be effectively drained away without causing drainage problem on top of the slab and the adjacent areas.

5.5 Services Within Drain/Drainage Reserve

5.5.1 No Services Within Drain or Drainage Reserve

No services, manholes or other services structures shall be laid within a drain or Drainage Reserve.

Where there is no Drainage Reserve, services, service manholes or other services structures shall be located at a minimum distance of 300 mm from the drainage structures.

5.5.2 Services to Undercross Drain/Drainage Reserve

Where services are approved to be laid within a drain or Drainage Reserve, the services shall be laid to undercross the drain/Drainage Reserve throughout the full width of the drain/Drainage Reserve with the following minimum clearance below the invert of the existing or proposed drain:-

- (a) 1.0 m for lined drain;
- (b) 1.5 m for earth drain or
- (c) other minimum clearance as may be specified by the Board.

5.5.3 Design Loading for Services within Drainage Reserve

Services located within a Drainage Reserve, if approved, shall be designed to withstand heavy vehicular loading in accordance with Land Transport Authority's standards and with their own independent supports.

5.5.4 Diversion of Services

Where new drains are to be constructed or existing drains are to be reconstructed, all existing services within or across the drains and Drainage Reserves shall be re-laid at the cost of the developer/owner to undercross the new or reconstructed drains.

5.5.5 Services Ducts in Culverts

Services ducts may be incorporated in the top slab of the culverts, subject to the approval of the Board.

6 REQUIREMENTS FOR CONSTRUCTION ACTIVITIES

6.1 General Requirements

- 6.1.1 The execution of any work shall not change, disrupt, fill, block, divert or disturb the existing overland flow or the existing system of drains unless an alternative drainage system has been approved by the Board.
- 6.1.2 The runoff within, upstream of and adjacent to the worksite shall be effectively drained away without causing drainage problems within the worksite or in areas outside the worksite.
- 6.1.3 All earth slopes shall be set outside the Drainage Reserve.
- 6.1.4 No obstruction of any kind shall be placed, laid or erected within Drainage Reserves and drains unless authorised by the Board. If so, the Drainage Reserves and drains shall remain accessible at all times to workers and plant/equipment of, or authorised by the Board.
- 6.1.5 No temporary structures such as cofferdams, crossings, stagings etc. shall be constructed in or over an existing drain without the approval of the Board.
- 6.1.6 Any temporary structure if approved within a drain or Drainage Reserve shall be removed immediately on completion of the construction works or as directed.
- 6.1.7 Drainage inlets such as drop-inlet chambers and scupper drains shall not be blocked by any material or debris.
- 6.1.8 Drains shall not be covered without the approval of the Board.
- 6.1.9 Bunds of stockpiled materials such as earth from trench work shall not be longer than 10 m and gaps of at least 1 m width shall be provided between the bunds to allow the free flow of surface runoff.
- 6.1.10 Material from any stockpile shall not be allowed to fall or be washed into the drain. Adequate preventive measures, including the provision of proper and stable barricades or screens where necessary, shall be provided.
- 6.1.11 Any damage to existing drain/drainage facilities arising out of any work shall be immediately reported to the Board. Any obstruction to flow arising from the damage shall be immediately and completely cleared. The damaged drain shall be repaired or reinstated to the requirements of the Board.

6.2 Laying and Diversion of Services

No services shall be laid or left (in conjunction with development works) within a Drainage Reserve. Where the services have to cross a Drainage Reserve, approval of the Board shall be obtained.

6.3 Earth Control Measures

6.3.1 *Water Quality Parameters to be Complied with*

The discharge from any construction / earthwork sites into storm water drainage system shall not contain Total Suspended Solids (TSS) in concentrations greater than, the prescribed limits under Regulation 4(1) of the Sewerage and Drainage (Surface Water Drainage) Regulations.

6.3.2 *Minimal or No Discharge*

A construction / earthwork site should practise recycling of water. The recycled water could be used for non-potable purposes in order to minimise discharge into the stormwater drainage systems.

6.3.3 *ECM Specifications in Tenders*

Developers / owners and Qualified Persons should include the earth control measures (ECM) specifications and schematic or conceptual ECM plans in the tender documents and allow for the cost of ECM in the tenders.

6.3.4 *Permit to start Earthworks*

The site operator / contractor shall obtain a written permission (or a clearance certificate) from the Board before the commencement of any earthwork.

6.3.5 *Submission of ECM proposal before commencement of works*

Before commencement of works, the site operator / owner shall engage a Qualified Erosion Control Professional (QECP) to plan and design a system of earth control measures (ECM) to meet the requirements cited in Clause 6.3.1.

The site operator / owner shall submit the detailed ECM proposal, endorsed by his QECP, to the Board for record, prior to the commencement of works. The ECM proposals (with calculations) shall include a plan (a typical plan is as shown in Drawing No. 8).

6.3.6 *Design Criteria of ECM*

The ECM shall be designed to cope with a minimum design rainfall intensity of a return period of 1 in 5 years storm.

6.3.7 *ECM to be installed before commencement of work*

The ECM shall be installed by the site operator / contractor according to the endorsed plans and the completed ECM at site shall be approved by the QECP before commencement of construction and earthworks.

6.3.8 **General Guidelines for Effective ECM**

An effective ECM requires 2 components which shall include, but is not limited to, the following minimum measures in order to meet the legal requirements cited under Regulation 4(1) of the Sewerage and Drainage (Surface Water Drainage) Regulations:

(A) Erosion Control Measures

The erosion control measures shall minimise the extent and duration of any exposed / bare / erodible surfaces by:

- a. *Proper Work Sequencing* - Adopting proper construction staging and work sequencing will help to ensure that no large bare / erodible surfaces are exposed for a long duration of time.
- b. *Covering up of all bare / erodible surfaces* - All bare surfaces (including earth stockpiles) shall be by concrete-lining, concrete-paving, milled waste, erosion control blankets, close turfing or other suitable materials. Accesses within the site and at exit / entrance as well as the surfaces where site facilities (such as office, fabrication and storage yards) shall be paved. For those work areas, they shall be covered by canvas sheets, tarpaulin sheeting or other suitable materials during rains or before work stops every day.
- c. *Progressive and timely revegetation and stabilisation* – This is to ensure that all bare surfaces are restored immediately upon completion of work at every stage.

If a construction site has very little bare / erodible surfaces, the operator / contractor will have less difficulty in containing and treating the silty discharges as described in Clause 6.3.8 (B) below. For those areas within a construction site which have been paved / covered and will not cause silty discharge, it is possible to drain these areas directly into the storm water drainage system without treatment.

(B) Sediment Control Measures

The sediment control measures shall trap, contain and treat the silty discharges from within a construction / earthworks site (including rain, runoff, water from washbay, underground water at basement, etc) by providing:

- a. *Perimeter Cut-off Drain* – Perimeter cut-off drains shall be concrete-lined and adequate to capture all runoff from the site. For sites located above slope, a boundary wall of at least 600 mm high shall be provided along the entire perimeter of the site to prevent overflow onto adjacent properties.
- b. *Perimeter Silt Fence* – Silt fences shall be erected along the perimeter cut-off drain (between the construction site and perimeter cut-off drain). The silt fence is to be embedded firmly into the ground and made from an approved geotextile filter fabric or equivalents to capture the sediment from stormwater runoff. The sediment built-up behind the silt fence must be regularly removed.
- c. *Intermediate Silt Trap* – Intermediate silt traps of suitable size shall be installed at regular intervals along the perimeter lined cut-off drain. Within the intermediate silt traps, suitable geotextile filter fabric or equivalents shall be installed across the full depth and width and / or coagulation-assistance materials shall be placed. Silt traps relying primarily on hardcore, granite chips or sands for filtration, are not acceptable.

d. *Sedimentation Basin or Storage Pond / Tank* - Before silty discharge leaves the site, the silt and sediments shall be separated from the water. This can be achieved by either:

- i. in a sedimentation basin / pond (which will take days for settlement to take place and a large basin volume), or
- ii. through a treatment system–cum–storage tank.

The basin / tank shall have a storage capacity to cope with the volume of water from a rain based on a minimum design return period of 1 in 5 years storm.

e. *Treatment System* – If the design of a sedimentation basin cannot meet the TSS requirement, then other suitably-sized treatment system shall be installed to treat all silty discharge from construction and earthwork sites. The treated effluent could be recycled for non-potable use.

f. *Turbidity Curtains* - For works in or adjacent to water bodies, such as canals, rivers, sea or in a reclamation work, turbidity curtain(s) shall be installed along all the exposed slopes / riverbanks. The silty discharge trapped within the turbidity curtain shall be allowed to be settled or treated, and the settled silt removed.

g. *Wheel wash* – the waters used to wash the wheels of the trucks / vehicles shall not be discharged into stormwater drainage system at any time. The silty water within the wheel wash basin shall be connected to the sedimentation basin / treatment system. The silt collected at the bottom of the wheel wash shall be removed.

6.3.9 ***Review of ECM during Contract duration***

The site operator/ contractor shall ensure that the ECM designed and installed shall be continuously reviewed by the QECP for every stage of the construction and earthworks. The ECM shall remain effective throughout the whole duration of works. The site operator / contractor shall add or amend the ECM at site according to the design of the QECP.

6.3.10 ***Maintenance of ECM during Contract duration***

The site operator / contractors shall operate and maintain the ECM regularly to ensure the ECM remains effective throughout the whole duration of works. This may involve replacing of silt fences and erosion control blankets or re-paving of concrete surfaces or replacing of membrane module or polymers blocks.

6.3.11 ***Monitoring of Discharge during Contract duration***

The site operator/ contractor shall monitor the discharge water quality as cited in Clause 6.3.1 before it enters the storm water drainage system. The site operator/ contractor shall for this purpose provide a continuous monitoring system which include the necessary monitoring instrument and CCTV system upon requested by the Board for their ECM. The site operator/ contractor shall submit regular reports (including photographic and monitoring records) of the site ECM as well as those for discharge quality to the Board over the whole duration of the project.

6.3.12 ***Removal upon Completion***

The ECM shall not be removed before the completion of work. The site operator/ owner shall inform the Board prior to removal of the ECM on completion of the project

6.4 Earthworks

- (a) The approval of the Board shall be sought for all earthworks affecting the existing drainage system or the flow pattern of surface runoff. In the event that earthworks are to be carried out adjacent to major drains and canals, the developer/owner shall engage a Qualified Person to carry out soil investigation works and slope stability analysis to ensure that the earthworks will not cause any damage to the drainage structures.
- (b) The developer/owner shall take all necessary steps and measures, such as implementing suitable soil stabilisation methods and temporary protection works to ensure the stability and structural integrity of the existing drainage structures.
- (c) Earth control measures shall be provided in accordance with the requirements as stipulated in Section 6.3.

6.5 Roadworks

A temporary drainage system shall be provided for all roadworks to prevent flooding or water ponding on the road. Where the road is being raised and the new road drainage outlets are at a higher level than the existing ones, the existing outlets shall not be blocked unless temporary alternative drainage system has been provided. The developer/owner and the Qualified Person shall be responsible for implementing all necessary measures to ensure that the site is kept flood free at all times. Where necessary, the Board may require the submission of hydraulic calculations, programme of works, temporary drainage arrangements at various stages of the roadworks, etc by the Qualified Person.

6.6 Reclamation Works

- 6.6.1 All reclamation works shall be carried out in accordance with Sections 2.3 and 4.11.
- 6.6.2 During reclamation, a temporary drainage system including perimeter cut-off drains, silt-traps, silt fences and outlet connections shall be provided. The temporary drainage system shall include erosion protection linings, such as concrete, geotextile mattress and other suitable materials to be approved by the Board. The proposals of the temporary drainage system shall be submitted to the Board for approval.
- 6.6.3 The temporary drainage system shall be cleansed and maintained regularly by the reclamation agency to remove all obstructions, silt and rubbish during the reclamation period.

CODE OF PRACTICE ON SURFACE WATER DRAINAGE

PART II

DESIGN REQUIREMENTS

- 7 Drainage Design And Considerations
- 8 Aesthetic Treatment of Watercourses and Integration of Adjacent Watercourses with Developments
- 9 Drainage Structures And Facilities
- 10 Pumped Drainage System

CODE OF PRACTICE ON SURFACE WATER DRAINAGE

PART II

DESIGN REQUIREMENTS

7 DRAINAGE DESIGN AND CONSIDERATIONS

7.1 Computation of Peak Runoff

7.1.1 Rational Formula

The Rational Formula shall be used to compute the peak runoff:-

$$Q_r = \frac{1}{360} CIA$$

where Q_r = peak runoff at the point of design (m^3/s)

C = runoff coefficient

I = average rainfall intensity (mm/hr)

A = catchment area (hectares)

7.1.2 Runoff Coefficient

The runoff coefficient (C) depends on the degree and type of development within the catchment. Catchments are classified according to the expected general characteristics when fully developed. The C values are as follows:-

Characteristics of catchment when fully developed	Value of C
Roads, highways, airport runways, paved up areas	1.00
Urban areas fully and closely built up	0.90
Residential/industrial areas densely built up	0.80
Residential/industrial areas not densely built up	0.65
Rural areas with fish ponds and vegetable gardens	0.45

Note: For catchments with composite land use or surface characteristics, a weighted value of C may be adopted.

7.1.3 Rainfall Intensity

For a storm of return period (T) years, the rainfall intensity (I) is the average rate of rainfall from such a storm having a duration equal to the time of concentration (t_c). The rainfall intensity (I) can be obtained from the Intensity-Duration-Frequency (IDF) curves by estimating the duration of rainfall (equals to the time of concentration, t_c) and selecting the required return period of (T) years. The Intensity-Duration-Frequency (IDF) curves for Singapore Island are shown in Appendix 4.

The return periods (T) adopted for the design of drainage systems in Singapore are as follows:-

Area Served by Drainage System	Return Period (T)
Catchment of less than 100 ha	10 years
Catchment of 100 to 1000 ha	25 years
Catchment of more than 1000 ha or critical installations	50 to 100 years

7.1.4 Time of Concentration

The peak runoff (Q_r) occurs at the point of design when all parts of the catchment receiving a steady, uniform rainfall intensity are contributing to the outflow at this point. This condition is met when the duration of rainfall equals the time of concentration (t_c). The time of concentration (t_c) consists of the overland flow time (t_o) plus the drain flow time from the most remote drainage inlet to the point of design (t_d), viz. $t_c = t_o + t_d$.

The overland flow time (t_o) varies from 5 minutes to 15 minutes, depending on the overland travel distance, land topography and characteristics. The drain flow time (t_d) shall be estimated from the hydraulic properties of the drainage channel.

7.1.5 Maximum Allowable Peak Runoff

Industrial, commercial, institutional and residential developments greater than or equal to 0.2 hectares in size are required to control the peak runoff discharged from the development sites. The maximum allowable peak runoff to be discharged to the public drains will be calculated based on a runoff coefficient of 0.55, and for design storms with a return period of 10 years and for various storm durations of up to 4 hours (inclusive). Peak runoff reduction can be achieved through the implementation of ABC Waters design features and structural detention and retention features, such as:

- a) Detention tanks;
- b) Retention/sedimentation ponds;
- c) Wetlands;
- d) Green roofs;
- e) Planter boxes;
- f) Bioretention swales;
- g) Porous pavements;
- h) Bioretention basins or rain gardens, etc.

The QP shall be required to submit details (calculations and/or hydraulic model results) showing how the proposed system meets the required peak runoff rates. Due consideration shall be given to meeting ABC Waters stormwater quality objectives, which will often require treatment of stormwater runoff using ABC Waters design features. For design guidance on the ABC Waters design features, QPs can refer to the ABC Waters Guidelines and relevant chapters in the Engineering Procedures, available on the PUB website.

7.2 Computation of Discharge Capacity

7.2.1 Steady Uniform Flow Condition

Drains are designed for steady uniform flow conditions and one-dimensional method of analysis is used.

7.2.2 Manning's Formula

Drains shall be designed to have discharge capacities (Q_c) adequate to cope with the estimated peak runoffs (Q_r). The size, geometry and the bed gradient of a drain determine its discharge capacity (Q_c). With the required discharge capacity (Q_c) determined [which must be equal to or larger than the peak runoff (Q_r)], the size of the drain is computed from

$$Q_c = \frac{1}{n} A R^{\frac{2}{3}} S^{\frac{1}{2}}$$

the Manning's Formula:-

where Q_c = discharge capacity of drain (m^3/s)

n = roughness coefficient

A = flow area (m^2)

P = wetted perimeter (m)

R = A/P = hydraulic radius (m)

S = bed gradient

7.2.3 Roughness Coefficient

The value of the roughness coefficient (n) depends on the drain's flow surface and is given below:-

Boundary Condition	Roughness Coefficient (n)
Unplasticised Polyvinyl Chloride(UPVC)	0.0125
Concrete	0.0150
Brick	0.0170
Earth	0.0270
Earth with stones and weed	0.0350
Gravel	0.0300

Note: Where there are different flow surfaces within a drain section, equivalent roughness coefficient may be used.

7.3 Design Considerations

7.3.1 Minimum Velocity and Dry Weather Flow

The velocity of flow in a drain shall not be lower than 1.0 m/s for self-cleansing action to take place. However, the flow rate during dry weather may fall to a low level where this minimum velocity cannot be achieved. The problem can be solved by introducing a small channel in the drain to confine the dry weather flow to a smaller flow section. The dimensions of such a dry weather flow channel depend on the width of the drain and are tabulated in Drawing No. 1.

7.3.2 Maximum Velocity

The velocity of flow in a drain shall not be too great to cause excessive scouring or hydraulic jumps. Hence the velocity of flow in a concrete-lined drain shall be limited to a maximum of 3.0 m/s or below the critical velocity, whichever is lower. For an earth stream, the maximum velocity shall be limited to 1.5 m/s. Further limitation of the maximum velocity shall be complied with when specified by the Board.

7.3.3 Sub-critical Flow

Drains are designed to carry sub-critical flows. Critical state of flow exists when the Froude Number is equal to one. An open channel flow at or near the critical state shall be avoided as under such a condition the water surface is unstable and wavy. In order to secure greater flow efficiency, channel flow shall be designed so that the Froude Number shall fall within the range from 0.8 decreasing to such minimum value as to achieve a practical flow depth and permissible flow velocity.

7.3.4 Freeboard

Freeboard refers to the depth from the top of the drain (cope/bank) to the top of the water surface in the drain at design flow condition. Sufficient freeboard shall be provided to prevent waves or fluctuation of the water surface from overflowing the cope/bank. Generally, a depth of freeboard equivalent to 15% of the depth of the drain is required.

8 INTEGRATION OF ADJACENT WATERCOURSES WITH DEVELOPMENTS AND ABC WATERS DESIGN FEATURES WITHIN DEVELOPMENTS

8.1 Integration of Adjacent Watercourses with Developments

- 8.1.1 As part of the Active, Beautiful, Clean Waters (ABC Waters) Programme, integration of adjacent watercourses with proposed developments is encouraged, whilst satisfying the engineering requirements for drainage functions without posing any public safety, maintenance or environmental problems. These include, but are not limited to:
- (a) Enhancing the accessibility or connectivity to waterbodies/waterways, eg. creating community spaces for adjacent to watercourses and providing boardwalks to bring people closer to water, etc.;
 - (b) Providing aesthetic treatment to waterways, eg. use of a more natural finish such as block pitching or imprints on canal walls, planting along the canal walls, etc.;
 - (c) Installing ABC Waters Design features to detain and treat storm water runoff closer to the source (see Section 8.2 for further details).
- 8.1.2 The designs of the aesthetic waterbodies, waterways and safety barriers need not be constrained by the standard features as shown in this Code of Practice as long as these facilities fulfill the drainage requirements and do not give rise to any public safety, maintenance or environmental problems.
- 8.1.3 The approval of the competent planning authorities shall also be sought for all such proposals. Where appropriate, the aesthetic waterbodies and watercourses shall be integrated into the development proposals and be maintained by the developers/owners of these developments.

8.2 Integration of ABC Waters Design Features within Developments

- 8.2.1 Qualified Persons together with the developer/owner can significantly enhance the development by incorporating into their designs appropriate ABC Waters Design features as described in the latest version of “ABC Waters Design Guidelines” and “Engineering Procedures for ABC Waters design features” published by the Board (available at <http://www.pub.gov.sg/abcwaters>). These guidelines were developed based on the following principles:-
- (a) Reduction of runoff and peak flow from the development site by implementing local ABC Waters design features that provide detention measures and minimise impervious areas;
 - (b) Improvement of quality of water draining from the development into receiving environment. For example, through effective filtration and retention measures via ABC Waters design features, runoff from the site can be treated to remove pollutants and silt, thereby protecting the water quality in waterways downstream;
 - (c) Integration of stormwater treatment into the landscape by incorporating multiple-use ABC Waters design features that also maximise the aesthetics and recreational amenities of developments; and
 - (d) Protection and enhancement of natural water systems within the development site.

- 8.2.2 The developer/owner shall engage an ABC Waters (Active, Beautiful, Clean Waters) Professional to design, oversee the construction of, and develop a maintenance plan for the ABC Waters design features. The developer/owner shall submit the concept design and design calculations, endorsed by the ABC Waters Professional, to the Board as part of DC submission.
- 8.2.3 For ABC Waters design features that are designed to be part of the measures to comply with Clause 7.1.5, the developer/owner shall maintain the ABC Waters design features regularly to ensure that these features are well maintained and remain effective in serving the functions as stipulated in Clause 7.1.5. The developer/owner shall comply with the submission of documents as stipulated in Section 13.2.

9 DRAINAGE STRUCTURES AND FACILITIES

9.1 Drain and Culvert

The schematic details of U-shaped and trapezoidal drains and box culvert are shown in Drawing No. 1. Drains and culverts shall be designed to be hydraulically adequate, structurally sound and geotechnically stable in accordance with the current codes, specifications and requirements.

9.2 Roadside Drain

All roadside drains shall be constructed in accordance with the standard Land Transport Authority's specifications shown in Drawing No. 2 or such other drawings to be issued by Land Transport Authority or the Board. The roadside drains shall be provided with false bottom as may be required by the Board.

9.3 Transition

A transition is required where there is a change of drain cross-section. The purpose of a transition is to change the shape of flow and surface profile in such a manner that minimum energy losses occur and cross waves and other turbulence are reduced. This may be achieved using tapering walls with no sudden changes of cross-section. The minimum length of a transition shall be 1.5 times the width of the wider drain section.

9.4 Curve and Bend

9.4.1 The presence of curves or bends in drain alignment is sometimes unavoidable. Difficulties in design often arise because of the complexity of the flow around a curved path. A drain curve will increase frictional loss and lead to the danger of serious local erosion due to spiral flow. Hence, the radius of any horizontal curve shall be as large as possible, consistent with the general terrain, in order to reduce the super elevation of the water surface and preserve the freeboard. A horizontal curve shall have a minimum radius of 3 times the width of the drain channel.

9.4.2 The benching of the drain at the bend shall be configured to minimise sedimentation at the inner side of the bend. For this purpose, the dry weather flow channel at the bend shall be aligned towards the outer side of the bend, with the centre of the channel spaced at a quarter of the drain width from the outer cope of the drain.

9.5 Sump for Drain Intersections

A sump of sufficient size shall be provided where drains converge. The minimum internal width of the sump shall not be less than 1.5 times the width of the drain leading away from the sump. Drains shall enter the sump at angles less than a right angle and at different levels wherever possible. The invert level of the downstream drain shall be lower than the invert level of the sump so that no stagnant water will collect in the sump.

9.6 Maintenance Access for Drainage Reserve

9.6.1 The maintenance access within a Drainage Reserve shall be level and continuous. The requirements of the levelled maintenance access are shown in Drawing No. 3. If there is an approved structure overcrossing a Drainage Reserve, ramps (not steeper than 12%) shall be provided at both sides of the structure for the continuity of maintenance access.

- 9.6.2 Access from adjacent road to Drainage Reserve shall be provided. At the entrance of the access, detachable bollards or posts and chains shall be provided as shown in Drawing No. 4.

9.7 Markers along Edge of Drainage Reserve

If a Drainage Reserve is not fenced-out from the adjoining premises, concrete markers shown in Drawing No. 4 shall be installed at maximum 50 m spacings along the edge(s) of the Drainage Reserve to demarcate the Drainage Reserve line(s). Closer spacing may be necessary at curves/bends.

9.8 Drop-inlet Chamber and Slot-outlet

- 9.8.1 Runoff from road carriageways and carparks shall be effectively drained away to prevent water stagnation and to ensure road safety. Drop-inlet chambers and concealed scupper drainage shall be designed in accordance with the Land Transport Authority's standard specifications and shall be provided at maximum 6 m spacings along all road carriageways.

For flood prone areas, hotspots or any other areas as specified by the Board, enhanced drop-inlet chambers (shown in Drawing No. 5) shall be provided.

- 9.8.2 At all T-junctions of roads with one or more of the connecting side roads sloping down towards the junction, drop-inlet chambers shall be provided at half the normal spacings or alternatively, slot-outlets with gratings shall be provided as shown in Drawing No. 9. Slot-outlet may also be used where an existing roadside drain is less than 500 mm deep or at areas outside the road carriageways such as carparks.

9.9 Safety Railings

Standard safety railings shall be provided for all open drains more than 1.0 m deep. The railings shall be galvanised, painted and erected as specified in Drawing No. 6.

9.10 Special Railings for Park Connectors

If approved by the Board, special railings may be installed in conjunction with the development of park connectors or waterbodies. The railings shall be easy to maintain, safe and compatible with the surroundings. Special railings which have been approved for use are given in Drawing Nos. 7A & 7B.

9.11 Rungs in Drains

Non skid aluminium rungs shall be provided at 60 m apart for open drains with internal widths equal to or less than 2 m and at every opening/grating for closed drains with internal widths equal to or less than 2 m. Rungs shall be embedded in the drain wall as shown in Drawing No. 2.

9.12 Grating over Closed Drain/Culvert

- 9.12.1 All gratings provided over closed drains/culverts shall be hinged to fixed frames securely embedded into the drain structures. Mild steel heavy duty gratings shall be used for closed drains subjected to vehicular loadings, whereas light duty gratings shall only be used for pedestrian loadings. Chequered plates shall be fixed on the pedestrian gratings for those closed drains narrower than 2 m (internal width). The gratings, frames and chequered plates shall be galvanised. The details of the gratings and chequered plates shall be designed in accordance with the Land Transport Authority's standard specifications.

9.12.2 Where a culvert runs across the road, no sump/grating shall be sited on the road carriageway. Where necessary, sumps with galvanised mild steel grating shall be provided at the two side-tables of the road. In the case of a dual carriageway, a sump with galvanised heavy duty mild steel grating shall be provided at the centre divider.

9.12.3 The size and spacing of gratings required shall be based on the internal width of the closed drain, as follows:-

Internal Width (W)	Grating	
	Size	Spacing
W > 4 m	850 mm x 1000 mm	50 m (staggered)
	in addition 3.5 m x 1.8 m (opening)	500 m
2 m < W ≤ 4 m	850 mm x 1000 mm	50 m (staggered)
	in addition 1.5 m x 1.5 m (opening)	500 m
750 mm < W ≤ 2 m	850 mm x 1000 mm	6 m (for drain ≤ 1 m deep) or 18 m (for drain > 1 m deep)
600 mm ≤ W ≤ 750 mm	700 mm x 850 mm	6 m
<p>Note: (i) Rungs shall be embedded at the drain wall at every opening/grating for closed drains with internal widths equal to or less than 2m in accordance with Section 9.11.</p> <p>(ii) Chequered plates shall be fixed on the pedestrian gratings for closed drains with internal widths less than 2m.</p>		

9.12.4 Where a closed drain exceeds 3 m deep, access shaft (2 m by 1.5 m) may be required by the Board. If the access shaft is deeper than 4 m, intermediate platform shall be provided as shown in Drawing No. 9.

9.13 Entrance Culvert/Crossing

Where an entrance culvert/crossing is proposed at a stretch of closed drain, gratings/openings shall be provided at the closed drain sections immediately upstream and downstream of the proposed entrance culvert/crossing.

Under the exceptional circumstance where the entrance culvert/crossing is shallower than 600 mm, hinged open gratings shall be installed throughout the whole length of the entrance culvert/crossing.

9.14 Live Loads on Drains

- 9.14.1 In the design of drains, stability of the slope and upheaval shall be considered. A nominal live load surcharge of 10 kN/m^2 shall be taken into consideration in the design of drains except as qualified by Clause 9.14.2.
- 9.14.2 For drains that are adjacent to roads and are affected by vehicular loading, a live load surcharge of 20 kN/m^2 shall be taken into consideration in the design of drains.
- 9.14.3 Culverts carrying vehicular loading shall be designed to withstand bridge loading in accordance with Land Transport Authority's standards.

10 PUMPED DRAINAGE SYSTEM

10.1 The minimum design and operation criteria for the pumped drainage system shall be as follows:-

- (a) the pumping capacity shall be adequate to cater for immediate discharge of the storm water ingress of not less than 150 millimetres per hour from the entire source catchment area; i.e:

$$P > \frac{IA}{3.6 \times 10^6}$$

where P = pumping capacity (m³/s)

I = rainfall intensity (mm/hr)

A = catchment area contributing to ingress of storm water (m²)

- (b) there shall be a complete set of back-up pumping equipment, including back-up pumps, pumping mains, generators and their appurtenances for back-up power supply.
- (c) the pumping installation shall be designed with an automated device to start the pumping operation at times of storm water ingress, with operational option for manual control to override the automated device whenever desired.
- (d) adequate pump sump shall be provided with sufficient storage capacity to cater for the total quantum of inflow from the entire source catchment area over a duration of at least 3 hours or such longer period as may be deemed necessary by the Qualified Person or as required by the Board for the re-activation of the pumping installation in the event of emergency breakdown/repairs or power failure, based on the maximum recorded rainfall given below:-

Duration (hrs)	3	4	5	6	12	24
Total Rainfall (mm)	196.9	210.6	253.4	281.9	376.7	533.2

- (e) the Qualified Person shall formulate and implement a well-regulated procedure for the maintenance, operation and monitoring of the pumped drainage system.
- (f) the base of the pump sump shall be designed with a gradient of 1:40 or steeper, and which shall be graded towards the pumps. The pumps shall be located within a small sump pit which should be deeper than the pump sump so that there will be no stagnant water in the pump sump at all times.

10.2 The criteria specified above are minimum requirements which shall be complied with. Nevertheless, the Qualified Person shall be fully responsible for the complete design of the pumped drainage system, incorporating such additional features or requirements as the Qualified Person may deem necessary to achieve fail-safe protection of the basements, tunnels or underground facilities against flood.

- 10.3** The civil and structural components of the pumped drainage system shall be designed and endorsed by a Professional Engineer (Civil) while the mechanical and electrical components shall be designed and endorsed by a Professional Engineer (Mechanical/Electrical). Design computations duly endorsed by the Professional Engineers shall be submitted to the Board for record including the operation sequence and monitoring measures of the pumped drainage system and other relevant information.
- 10.4** The developer/owner shall be responsible for the maintenance, operation and monitoring of the pumped drainage system. The Qualified Persons shall liaise with the developer/owner to ensure that a well-established management set-up is operational to undertake this function before applying for the issue of Temporary Occupation Permit and Certificate of Statutory Completion.
- 10.5** The Board may in special cases introduce amendments or additional requirements for the design and operation of the pumped drainage systems.

CODE OF PRACTICE ON SURFACE WATER DRAINAGE

PART III

ENSURING THE INTEGRITY OF STORM WATER DRAINAGE SYSTEMS

- 11 Temporary Occupation Permit (TOP)
- 12 Certificate of Statutory Completion (CSC)
- 13 Maintaining the Integrity of Storm water Drainage Systems

CODE OF PRACTICE ON SURFACE WATER DRAINAGE

PART III

ENSURING THE INTEGRITY OF STORM WATER DRAINAGE SYSTEMS

11 TEMPORARY OCCUPATION PERMIT (TOP)

11.1 Compliance during Temporary Occupation Permit (TOP)

QPs are required to declare that their platform and crest protection levels are in compliance with the Code of Practice on Surface Water Drainage and constructed according to approved plans when applying for Temporary Occupation Permit (TOP) clearance.

The declaration shall consist of the application for TOP clearance and be supported by as-built survey plans indicating the crest levels, platform levels and flood protection levels (based on the approved flood protection measures), where applicable, and any other relevant information as required by the Board, prepared and endorsed by a registered surveyor. The Public Utilities Board will only issue TOP clearance through CBPD to the developer/ owner when the declaration and all necessary supporting documents are submitted and assessed to be in compliance with the requirements of approved plans and the Code of Practice on Surface Water Drainage.

12 CERTIFICATE OF STATUTORY COMPLETION (CSC)

12.1 Drainage Works According to Approved Plan

Drainage works shall be constructed in accordance with the approved drainage plans, the Sewerage and Drainage Act (Chapter 294), the Sewerage and Drainage (Surface Water Drainage) Regulations and this Code of Practice.

12.2 Supervision

- (a) The Qualified Person shall comply with the relevant sections of the Sewerage and Drainage Act (Chapter 294).
- (b) The Qualified Person shall be fully responsible for the supervision and construction of drainage works based on the approved plan.
- (c) The Qualified Person shall notify the Board of any proposed deviation of works from the approved plan and obtain approval for the deviation by submitting drawings showing the amendments before proceeding with the works.
- (d) The Qualified Person shall, if necessary, notify/apply directly to all the relevant authorities such as the Land Transport Authority, National Parks Board and Environmental Health Department before carrying out drainage works and shall abide by the conditions stipulated by the relevant authorities.

12.3 Completion of Works

On completion of drainage works, the Qualified Person shall certify and submit to the Board a Certificate of Inspection for Drainage Works.

12.4 “As-Constructed” Drainage Drawing and Piling Record

On completion of drainage works, the Qualified Person shall submit the “As-constructed” drawings and piling records to the Board for record. “As-Constructed” drawings for the following two categories of drainage works need to be submitted:-

- (i) Drains and approved structures within Drainage Reserve and
- (ii) Roadside drains (except for those built in accordance with the Land Transport Authority's standard designs).

Submission requirements for “As- Constructed” drainage drawings are shown in Appendix 5.

12.5 Survey Plan

A survey plan shall be submitted if a development or structure is constructed within less than 300 mm from a Drainage Reserve. The survey plan shall consist of a site plan and cross-sections showing the development or structure and lot boundary in relation to the Drainage Reserve. The survey plan shall be prepared and endorsed by a Registered Surveyor.

12.6 Defects Liability Period

Drainage works to be handed-over to the Board shall have a one year Defects Liability Period. The Defects Liability Period shall commence from the date the Board gives no objection to the issue of the CSC. The developer/owner shall pay for the cost of rectification of defects in the drainage works during the Defects Liability Period.

12.7 Handing-over of Drain

Upon the expiry of the Defects Liability Period, the Qualified Person shall arrange for the handing-over of the drainage works to the Board after all the necessary or required rectification works are satisfactorily completed.

13 MAINTAINING THE INTEGRITY OF THE STORM WATER DRAINAGE SYSTEM INCLUDING FLOOD PROTECTION MEASURES

13.1 Responsibility of Developer/Owner

The developer/owner shall be responsible for the maintenance, operation and monitoring of the storm water drainage systems within their premises. These include, but are not limited to, regular adequacy checks on the flood protection measures such as minimum crest levels, detention/retention pond systems and pumped drainage system.

13.2 Submissions on Storm Water Drainage System (including Crest/Flood barriers/Pumped drainage system/ABC Waters design features)

13.2.1 Crest Level(s)

- i) For Commercial/ Multi-Unit Residential Developments with Basements (e.g. shopping malls, large office buildings and condominiums), the developer/owner shall, every three years upon obtaining the Temporary Occupation Permit (TOP), declare that the crest levels are in compliance with the Code of Practice on Surface Water Drainage and constructed according to the approved plans. When there is deviation from the approved plans, the declaration shall be supported by as-built survey plans indicating the crest levels, platform levels, adjacent road levels, and any other relevant information as required by the Board, prepared and endorsed by a Registered Surveyor.

When requested by the Board, this declaration shall be submitted **annually** upon obtaining the Temporary Occupation Permit (TOP).

- ii) For Special Underground Facilities and Developments with linkages to Special Underground Facilities, the developer/owner shall declare that the crest levels are in compliance with the Code of Practice on Surface Water Drainage and constructed according to approved plans annually upon obtaining the Temporary Occupation Permit (TOP). When there is deviation from approved plans, the declaration shall be supported by as-built survey plans indicating the crest levels, platform levels, adjacent road levels, and any other relevant information as required by the Board, prepared and endorsed by a Registered Surveyor.

13.2.2 Flood barriers/ Detention Tanks/ ABC Waters Design Features/ Pumped Drainage System

The developer/owner, when requested by the Board, shall submit the following documents (where applicable) annually upon obtaining the Temporary Occupation Permit (TOP):

- i) Certificate of inspection on flood barriers on-site including leak test complying with relevant international standards or any requirements specified by the Board and endorsed by a Civil/Mechanical Qualified Person (where applicable);
- ii) Amendments to the standard operating procedure (SOP) of the flood barrier endorsed by a Civil and/or Mechanical Qualified Person;
- iii) Certificate of inspection on the pumped drainage system (for the basement and/or detention tank) endorsed by a Mechanical or Electrical Qualified Person;
- iv) Records on the Operational Performance of Flood Protection Measures/Pumped Drainage Systems prior to the onset of the North East Monsoon season (Nov – Jan); and
- v) Certificate of inspection on an ABC Waters design features endorsed by ABC Waters Professional. The certificate of inspection shall contain a declaration that the features have been inspected, and are maintained satisfactorily and functioning well.

DRAINAGE RESERVE REQUIREMENTS			
INTERNAL WIDTH OF DRAIN W	TYPICAL CROSS-SECTION	MINIMUM DRAINAGE RESERVE D	
		FOR OPEN DRAIN	FOR CLOSED DRAIN
1.0m TO 1.2m		3.0m	W+0.6m
>1.2m TO 3.0m		W+2.6m	W+1.6m
>3.0m TO 4.5m		W+3.5m	W+1.6m
>4.5m TO 6.0m		W+4.5m	W+3.0m
>6.0m TO 9.0m		W+6.0m	W+3.0m
>9.0m TO 25.0m		W+7.5m	W+3.0m
> 25.0m		W+12.0m	W+3.0m
		SEE DRAWING NO.3 FOR DETAILS.	

SUBMISSION REQUIREMENTS FOR FLOOD PROTECTION MEASURES**1) During Development Control (DC) stage**

For all developments with flood protection measures, the following documents, endorsed by a Qualified Person, shall be submitted:

- (i) Proposed plans indicating the crest levels and/or platform level with and without flood barrier at various entrance and exit points;

2) During Building Plan (BP) stage

For developments where flood barriers are automated and/or with more than 2 points of entry/ exit, or when requested by the Board, the following shall be submitted:

- (i) Proposed size, type and design of the flood barrier.
- (ii) Details on the standard operating procedure (SOP) including the proposed maintenance plan of the flood barrier to be endorsed by a Civil and/or Mechanical Qualified Person, and the developer owner.

3) During Temporary Occupation Period (TOP) stage

For all developments with flood protection measures, the following documents, endorsed by a Registered Surveyor, shall be submitted together with the declaration that their platform and crest levels are in compliance with the Code of Practice on Surface Water Drainage and constructed according to approved plans:

- (i) As-built survey plans indicating the crest levels, platform levels and the flood protection levels (based on the approved flood protection measures).

4) Certificate of Statutory Completion (CSC) stage

For developments where automated flood barriers are implemented, the following documents, endorsed by a Qualified Person (Civil and/or Mechanical), shall be submitted:

- (i) Leak Test Certification on the installed flood barrier, in compliance with relevant international standards or any requirements specified by the Board.

5) Maintaining the Integrity of the Storm Water Drainage System including Flood Protection Measures

The developer/owner of premises with flood protection measures, when requested by the Board, shall comply with the submission of documents upon obtaining the Temporary Occupation Permit (TOP) as stipulated in Section 13.2.

PRINCIPLES AND STANDARDS FOR FLOOD PROTECTION OF UNDERGROUND RAPID TRANSIT SYSTEM

The Underground Rapid Transit System must be stringently protected against flood risks. The salient principles and standards of protection to be complied are outlined below:-

(A) STRINGENT CATCHMENT SEGREGATION

[segregating the Underground Rapid Transit System from surface catchments and runoffs]

- absolutely minimise the storm catchments of the Underground Rapid Transit System (such as by means of profile designs and roofing), and channel all at-grade and above-grade runoffs (eg. that from the roofs) into surface drains segregated from the underground facilities.
- segregate the Underground Rapid Transit stations and tunnels by means of integrated water-tight barriers of at least 1metre above flood and ground levels.
- all ingress and egresses to the Underground Rapid Transit System (including pedestrian/traffic linkages and ventilation/services openings) are to be built with a segregation threshold of at least 1metre above flood and ground levels.

(B) FAIL-SAFE PUMPED DRAINAGE FACILITIES

[for removal of any water ingress that cannot be cut-off owing to constraints inherent in the Underground Rapid Transit System's interface with the surface tracks and linkages]

- install an active pumping capacity equivalent to the 100-year return storm intensity corresponding to the time of concentration of the storm catchment (excluding the internal infiltration route of the tunnel surface) as determined from the Code of Practice on Surface Water Drainage, capped at 280mm/hour for a typical 10-minute concentration duration.
- provide duplicated standby pumping facilities.
- install standby fuel generators for uninterrupted operation of the pumping facilities.
- construct pump sumps with an active operational storage capacity of 280mm (for 6-hour inflow) where sumps are accessible during train operations or 530mm (for 24-hour inflow) where sumps are inaccessible during train operations.
- institute a well-regulated maintenance and operation procedure for the pumped drainage facilities.

(C) DEVELOPMENT CONTROL OF ALL CONNECTED DEVELOPMENTS

[such that the same principles and standards of flood protection in (A) & (B) above are applied to all developments/facilities with existing/proposed linkages to the Underground Rapid Transit System]

- carry out advanced, comprehensive planning of all proposed linkages to the Underground Rapid Transit System.
- implement the same flood protection safeguards mentioned above for all such developments.

(D) OPERATIONAL AND MANAGEMENT CONTROL

[to ensure continued functioning and safeguarding of the protection measures implemented under (A), (B) & (C)]

- have in place a comprehensive map/database of the overall underground networks with linkages to the Underground Rapid Transit System.
- subject all building and development planning (including Addition & Alteration and reconstruction) of such linked developments/facilities to the vetting and control of the Land Transport Authority.
- institute stringent operational and management measures to be undertaken by the owners of the linked developments/facilities under the supervision of Land Transport Authority.

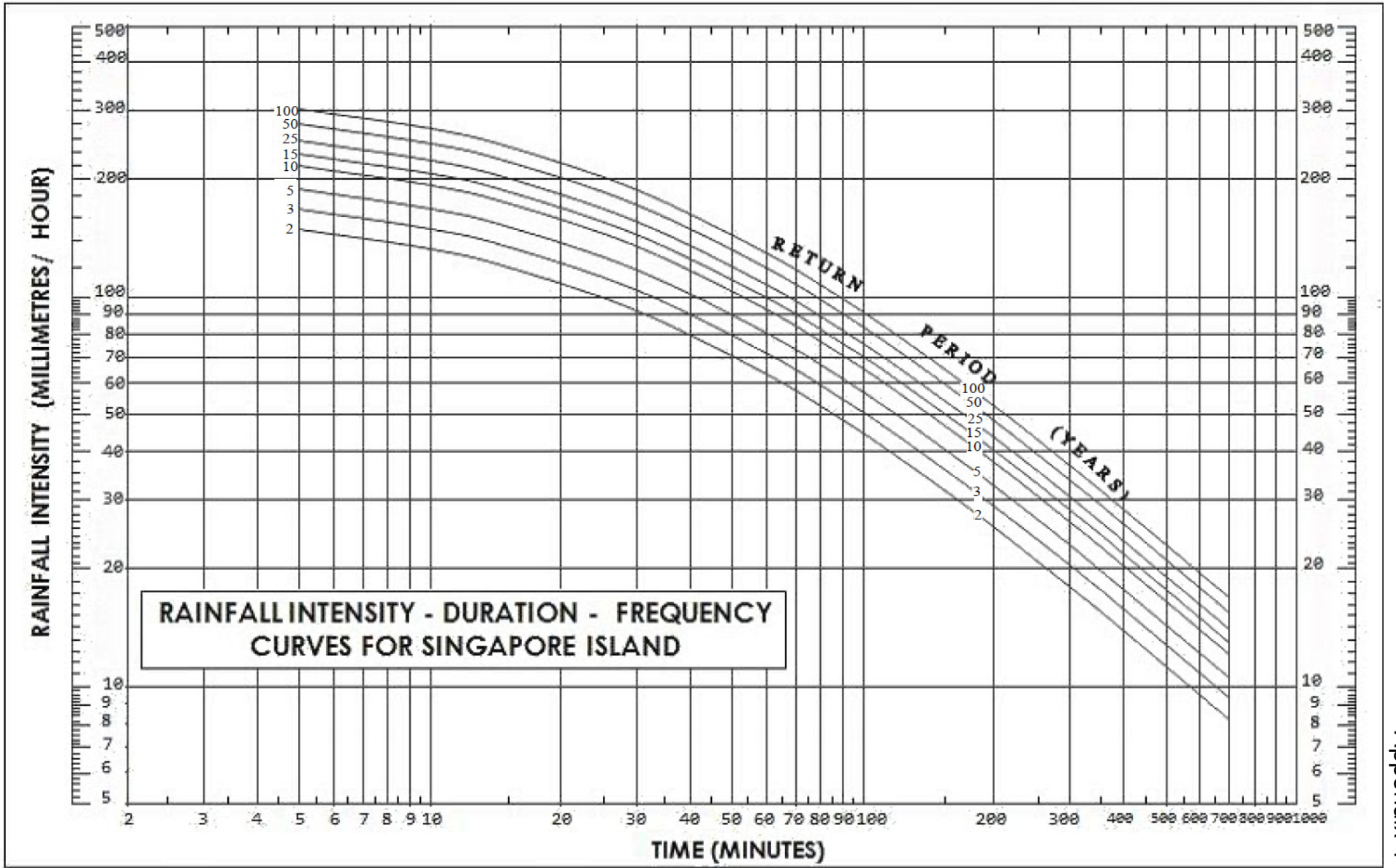

SUBMISSION REQUIREMENTS FOR “AS-CONSTRUCTED” DRAINAGE DRAWINGS

- (a) Two sets of the “As-Constructed” drawings shall be submitted. The “As-Constructed” drawings shall be endorsed by a Professional Engineer and, where applicable, also by a Registered Surveyor.
- (b) The “As-Constructed” drawings shall show the following details:-
 - (i) alignment and width of the Drainage Reserve.
 - (ii) size and type of the constructed drain within the Drainage Reserve.
 - (iii) longitudinal section showing the gradient, invert and cope level of the constructed drain.
 - (iv) cross-section of the constructed drain in relation to the Drainage Reserve/lot boundary/retaining wall/boundary fence.
 - (v) locations, sizes and types of all drain connections.
 - (vi) piling records for drains and structures within the Drainage Reserve and roadside drains including entrance culverts. The piling records shall include the extent of piling, sizes, types, lengths and spacing of the piles. Reasons shall be stated if no piling is carried out.
 - (vii) details of structures within Drainage Reserve such as bridge, crossing over drain, pedestrian crossing.
 - (viii) structures (including piling records) beside Drainage Reserve, as and when required by the Board.

This drawing shows schematically the drainage channels and minimum structural requirements. Details of the structural, geotechnical and foundation systems are to be designed by Qualified Persons.

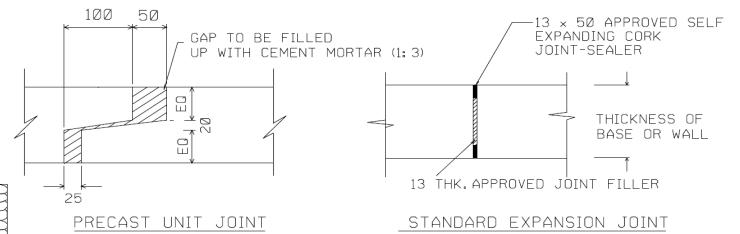
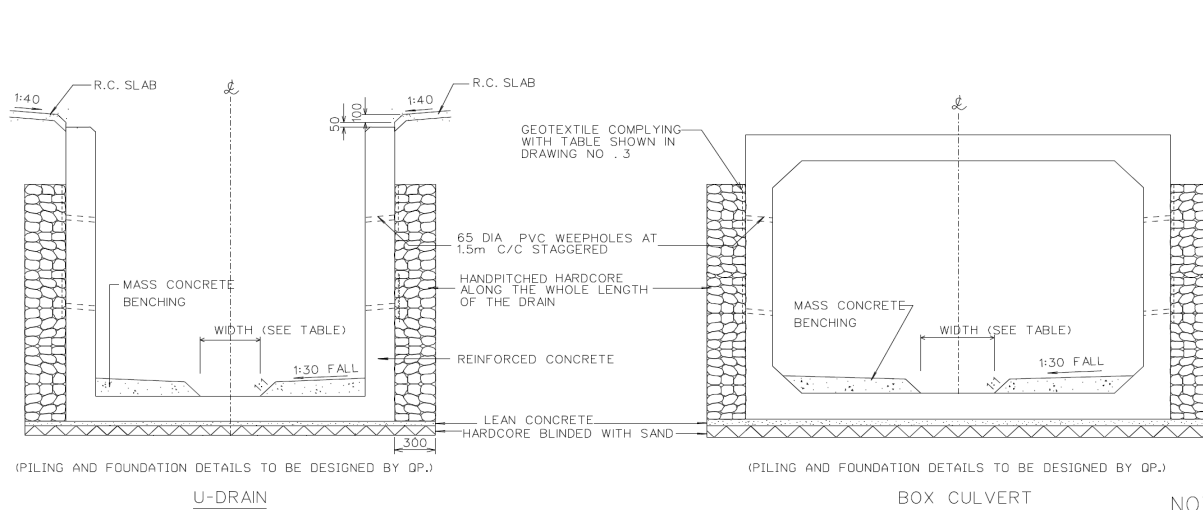

TOP WIDTH OF DRAIN	BOTTOM WIDTH OF D.W.F.	DEPTH OF D.W.F.
< 3.0m	0.3m	0.125m
≥ 3.0m TO 4.5m	0.6m	0.150m
> 4.5m TO 6.0m	0.9m	0.150m
> 6.0m TO 9.0m	1.2m	0.200m
> 9.0m TO 12.0m	1.8m	0.250m
> 12.0m	2.1m	0.300m

NOTES:

- EXPANSION JOINTS SHALL BE PROVIDED AT MAX. 35m INTERVALS AT THE BASE AND WALLS OF ALL CAST-IN-SITU DRAINS. SUCH JOINTS SHALL HAVE A GAP OF 13mm PACKED WITH AN APPROVED JOINT FILLER AND CAULKED WITH AN APPROVED SELF EXPANDING CORK JOINT-SEALER. ALL REINFORCEMENTS SHALL NOT BE CARRIED THROUGH AN EXPANSION JOINT.
- ALL PRECAST UNITS SHALL BE LAID CLOSE. THE MAXIMUM ALLOWABLE GAP IS 50mm. ALL GAPS SHALL BE FILLED WITH 1:3 MIX CEMENT MORTAR.
- ALL PRECAST AND REINFORCED CONCRETE SHALL BE GRADE 30 OR HIGHER GRADES.
- ALL MASS CONCRETE SHALL BE GRADE 25 OR HIGHER GRADES.
- ALL LEAN CONCRETE SHALL BE GRADE 15.
- MILD STEEL AND HIGH TENSILE STEEL REINFORCEMENTS SHALL CONFORM TO SS2
- FABRIC MESH REINFORCEMENTS SHALL CONFORM TO SS2
- MINIMUM REINFORCED CONCRETE SLAB THICKNESS SHALL BE 150mm.
- MAIN REINFORCEMENTS SHALL HAVE MINIMUM CLEAR COVERS OF 70mm. (WATER FACE) AND 50mm (EARTH FACE)
- THE CONSTRUCTED DRAINS SHALL NOT CAUSE PONDING AT THE BANKMENTS OF U-DRAINS & TRAPEZOIDAL DRAINS AND AT THE TOP SLAB OF BOX CULVERT.
- IN THE DESIGN OF U-DRAINS, UPHEAVE MUST BE CONSIDERED. THE WALLS OF U-DRAINS SHALL BE DESIGNED TO WITHSTAND A LIVE LOAD SURCHARGE OF 10 kN/m² ON THE BANKS.
- IN THE DESIGN OF TRAPEZOIDAL DRAINS, STABILITY OF THE SLOPE AND UPHEAVE MUST BE CONSIDERED. A LIVE LOAD SURCHARGE OF 10 kN/m² ON THE BANKS SHALL BE TAKEN INTO ACCOUNT.
- FOR DRAINS THAT ARE ADJACENT TO ROADS AND ARE AFFECTED BY VEHICULAR LOADING, A LIVE LOAD SURCHARGE OF 20 kN/m² SHALL BE TAKEN INTO CONSIDERATION IN THE DESIGN OF DRAINS.
- BOX CULVERTS SHALL BE DESIGNED TO WITHSTAND BRIDGE LOADING IN ACCORDANCE WITH LAND TRANSPORT AUTHORITY'S STANDARDS.
- ALL DIMENSIONS ARE IN MILLIMETRES UNLESS OTHERWISE STATED.

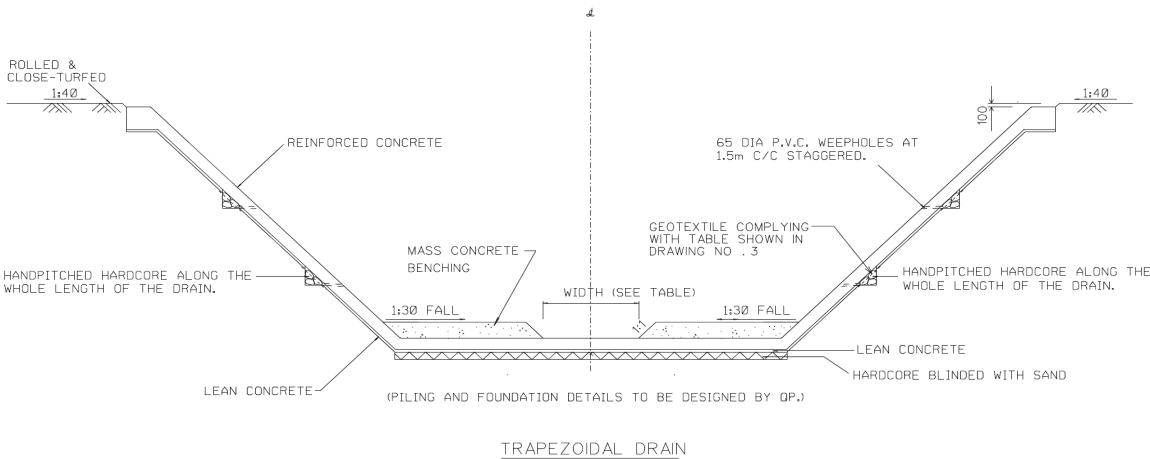

DRAWING NO. 1

U-SHAPED & TRAPEZOIDAL DRAINS AND BOX CULVERT

This drawing shows schematically the drainage channels and minimum structural requirements. Details of the structural, geotechnical and foundation systems are to be designed by Qualified Persons.

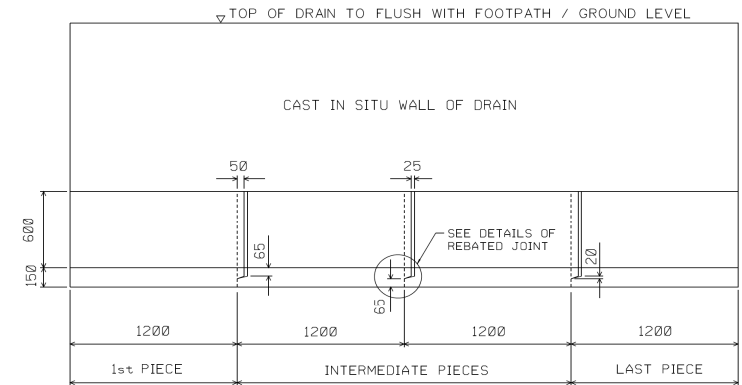
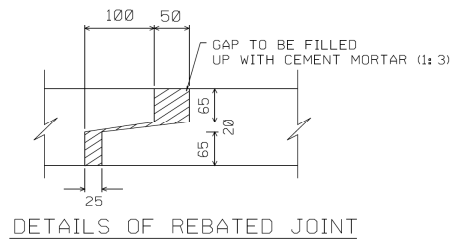
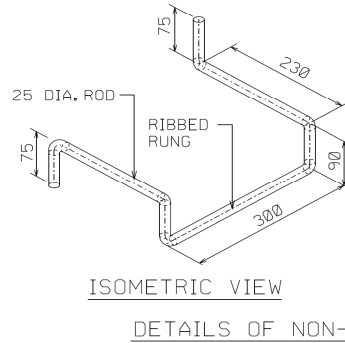
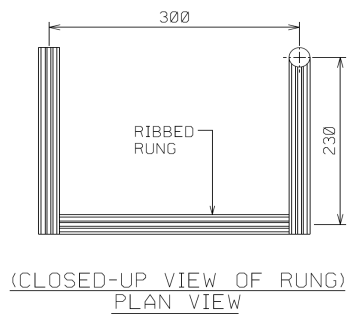
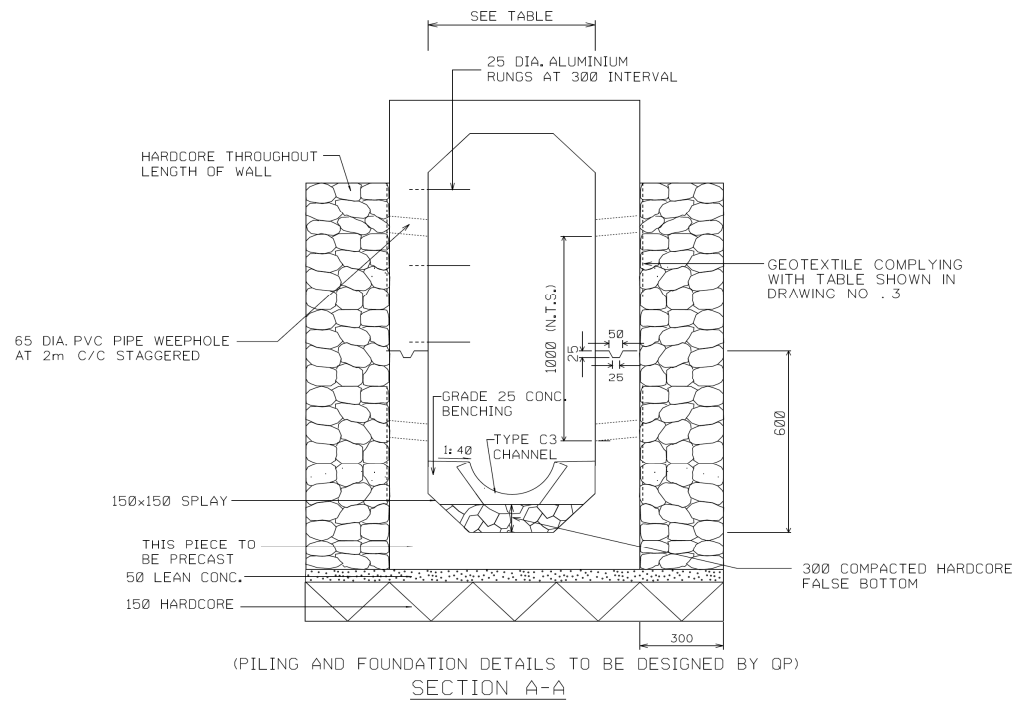

WIDTH OF DRAIN	600	750	900	1050	1200
----------------	-----	-----	-----	------	------

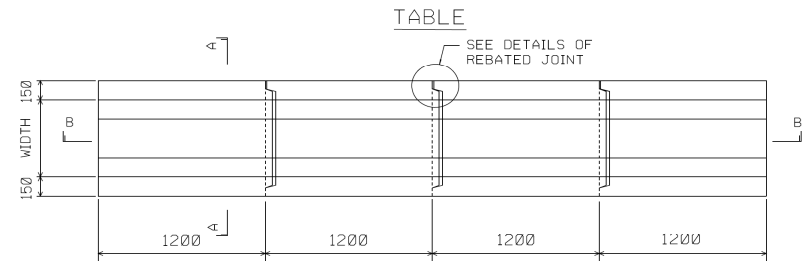

NOTES

1. CLEAR COVER TO REINFORCEMENT : 40mm.
2. GRADE 30 CONCRETE IS TO BE USED.
3. LENGTH OF PRECAST PIECE TO BE 1200mm ON STRAIGHT AND 500mm ON CURVES.
4. WIDTH / DEPTH RATIO OF DRAIN SHOULD NOT BE MORE THAN 1 : 2.
5. NON-SKID ALUMINIUM RUNGS ARE TO BE PROVIDED FOR ROADSIDE DRAINS WITH DEPTH EQUAL TO OR EXCEEDING 0.9m.
6. THE TOP SLAB OF THE ROADSIDE DRAIN SHALL BE CONSTRUCTED SUCH THAT PONDING AT THE TOP SLAB WILL NOT OCCUR.
7. ALL DIMENSIONS ARE IN MILLIMETRES UNLESS OTHERWISE STATED

This drawing shows schematically the drainage facilities and minimum structural requirements. Details of the structural, geotechnical and foundation systems are to be designed by Qualified Persons.

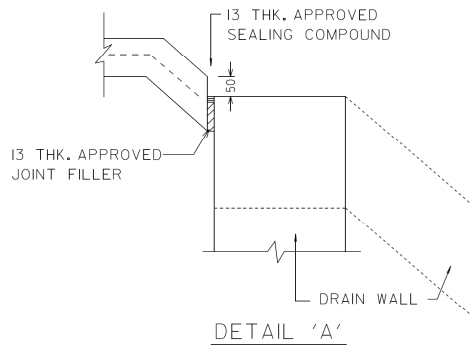

13mm THICK GAP EXPANSION JOINT

SYNTHETIC GEOTECHNICAL FABRIC MEMBRANE

THE FIBRE USED TO MANUFACTURE THE FABRIC SHALL CONSIST OF EITHER POLYPROPYLENE, POLYETHYLENE, POLYESTER, OR A COMBINATION OF THE AFORESAID MATERIALS. THE FABRICS SHALL HAVE THE PHYSICAL PROPERTIES COMPLYING WITH THE TABLE BELOW :

PHYSICAL PROPERTY	PHYSICAL PROPERTIES OF GEOTEXTILES		SPECIFICATION
	CLASS OF GEOTEXTILE		
	CLASS A	CLASS B	
MINIMUM UNIT WEIGHT, g/m ²	125	50	ASTM D3376
MINIMUM GRAB TENSILE STRENGTH, N	530	270	ASTM D1682
MINIMUM ELONGATION TO BREAK, %	60	55	ASTM D1682
MINIMUM TRAPEZOIDAL TEAR STRENGTH, N	180	80	ASTM D1117
MINIMUM MULLEN BURST STRENGTH, N/mm ²	1.10	0.50	ASTM D774
WATER PERMEABILITY, cm/sec	2.0x10 ⁻²	2.7x10 ⁻²	MANUFACTURER'S TEST REPORT TO BE SUBMITTED

NOTE:

- A. WHERE THE GEOTEXTILES SERVE A SEPARATION OR REINFORCEMENT FUNCTION, CLASS A GEOTEXTILES SHALL BE USED
- B. WHERE THE GEOTEXTILES SERVE A FILTRATION FUNCTION, CLASS B GEOTEXTILES SHALL BE USED.

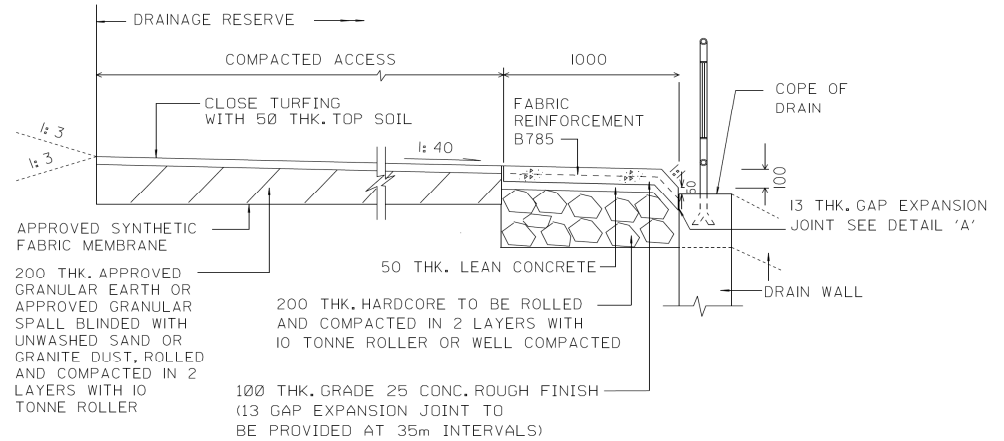

ACCESS WIDER THAN 1.8m

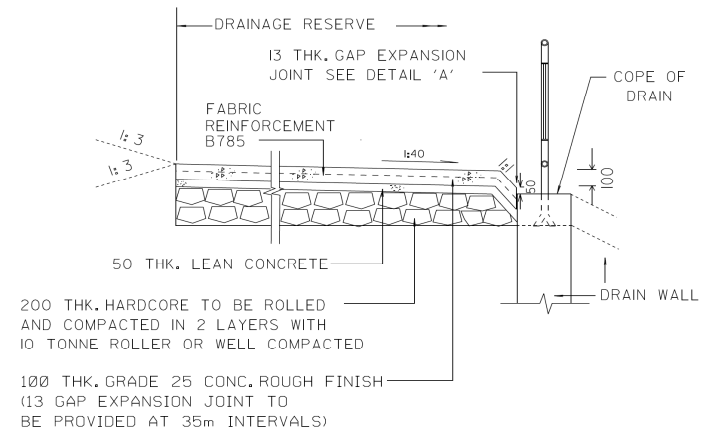

ACCESS UP TO 1.8m WIDE

NOTE: ALL DIMENSIONS ARE IN MILLIMETRES UNLESS OTHERWISE STATED.

DRAWING NO. 3

MAINTENANCE ACCESS FOR DRAINAGE RESERVES

This drawing shows schematically the drainage facilities and minimum structural requirements. Details of the structural, geotechnical and foundation systems are to be designed by Qualified Persons.

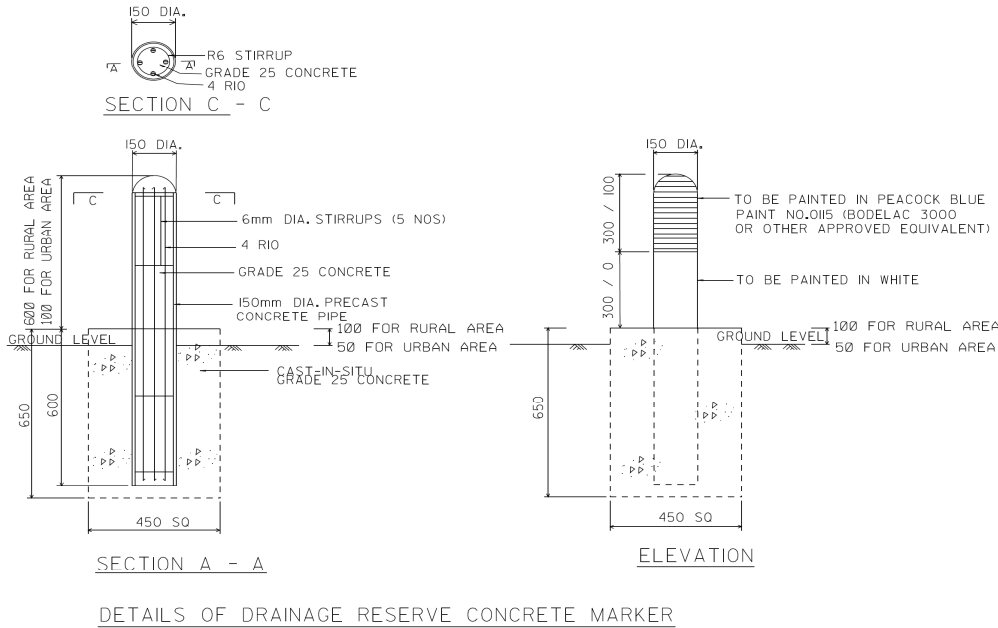

NOTES

1. ALL DIMENSIONS SHOWN ARE IN MILLIMETRES UNLESS OTHERWISE STATED.
2. MATERIALS
 - a) ALL G.S. PIPES OR EQUIVALENT TO BE LIGHT TUBES CONFORMING TO S.S.17
 - b) ALL STEEL USED TO BE MILD STEEL CONFORMING TO B.S.4360
 - c) ALL GALVANISING TO BE HOT DIPPED GALVANISED COATING CONFORMING TO S.S.117
3. GALVANISED STEEL PIPES TO BE PREPARED AND PAINTED AS FOLLOWS:
 - a) ONE COAT OF APPROVED WASH PRIMER
 - b) ONE COAT OF APPROVED ZINC CHROMATE PAINT
 - c) ONE UNDERCOAT OF APPROVED OIL BASED PAINT
 - d) TWO TOP COATS OF APPROVED OIL BASED PAINT
4. ALL STEEL RODS, FLAT & SQUARE TO BE PREPARED AND PAINTED AS FOLLOWS:
 - a) BEFORE ERECTION CLEAN WITH WIRE BRUSH TO REMOVE ALL RUST & MILL SCALE AND PAINT ONE COAT OF APPROVED PRIMING PAINT
 - b) AFTER ERECTION PAINT ONE UNDERCOAT OF APPROVED OIL BASED PAINT AND TWO TOP COATS OF APPROVED OIL BASED PAINT

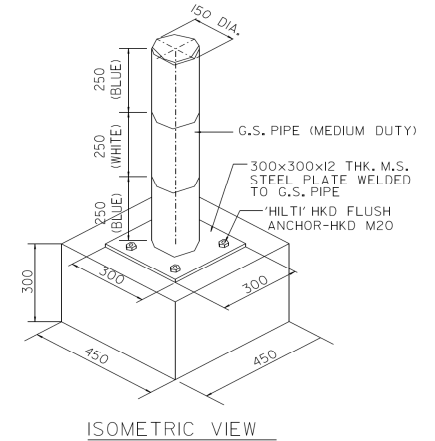
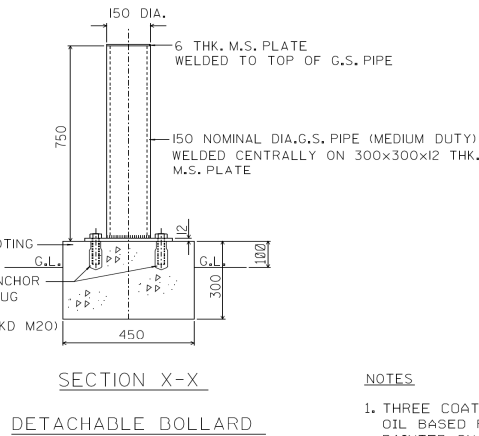
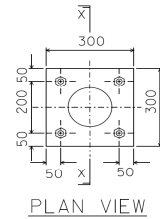
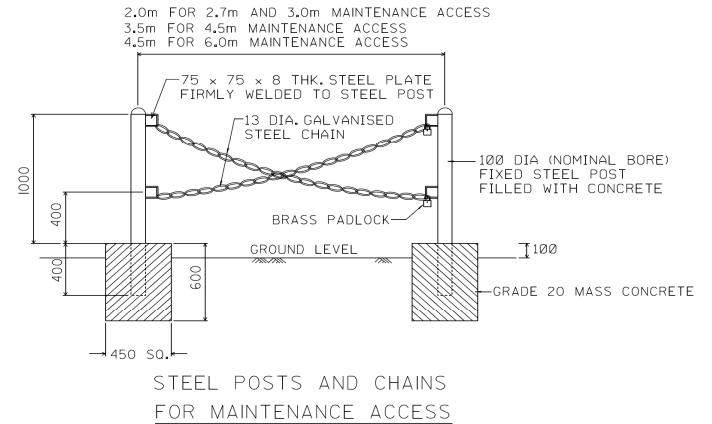

NOTES

1. THREE COATS OF APPROVED OIL BASED PAINT TO BE PAINTED ON BOLLARDS.
2. STEEL BASED PLATE BOLTS AND NUTS TO BE COATED WITH BITUMINOUS PAINT.

This drawing shows schematically the drainage facilities and minimum structural requirements. Details of the structural, geotechnical and foundation systems are to be designed by Qualified Persons.

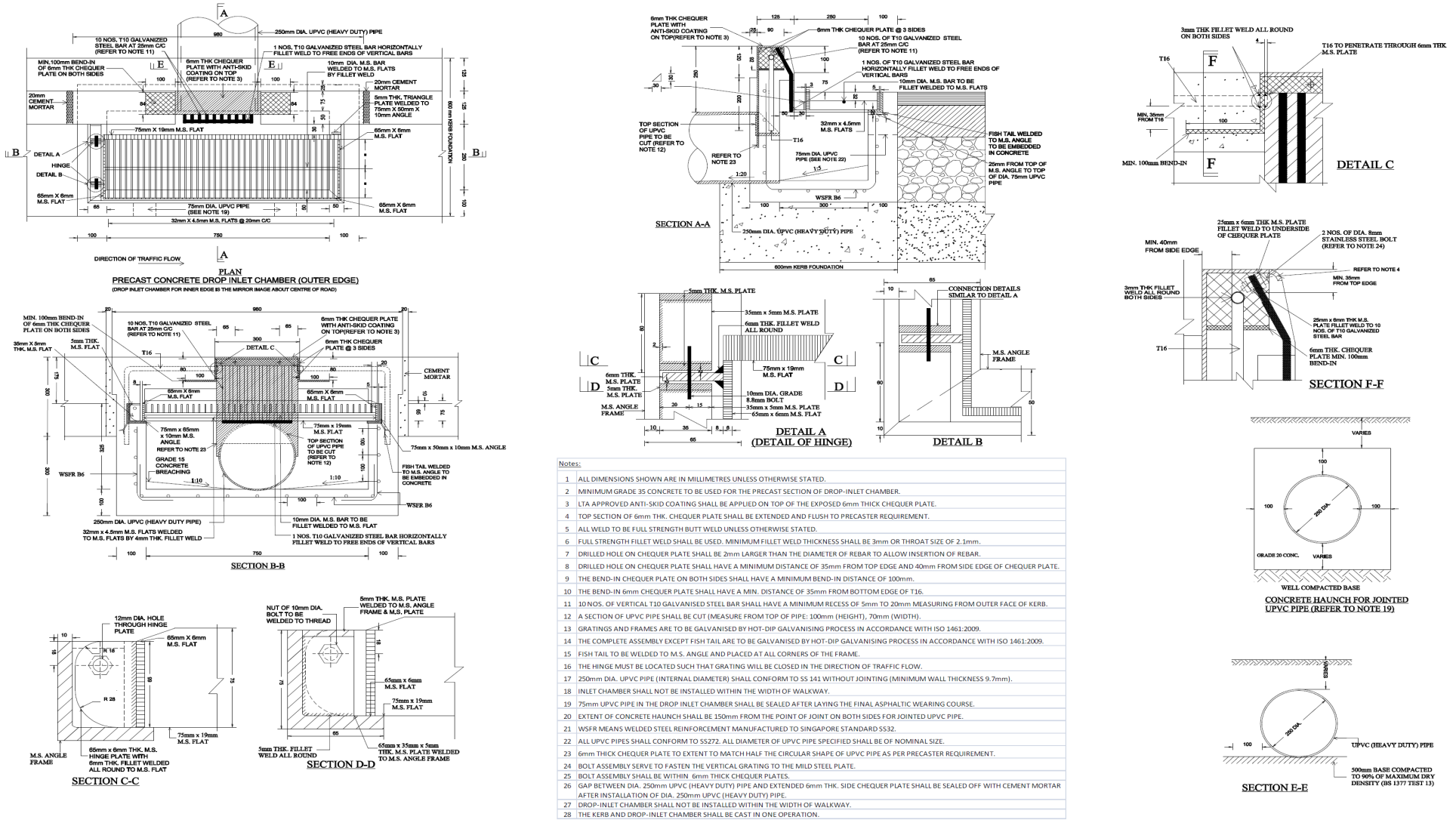

DRAWING NO. 5

ENHANCED DROP-INLET CHAMBERS

This drawing shows schematically the drainage facilities and minimum structural requirements. Details of the structural, geotechnical and foundation systems are to be designed by Qualified Persons.

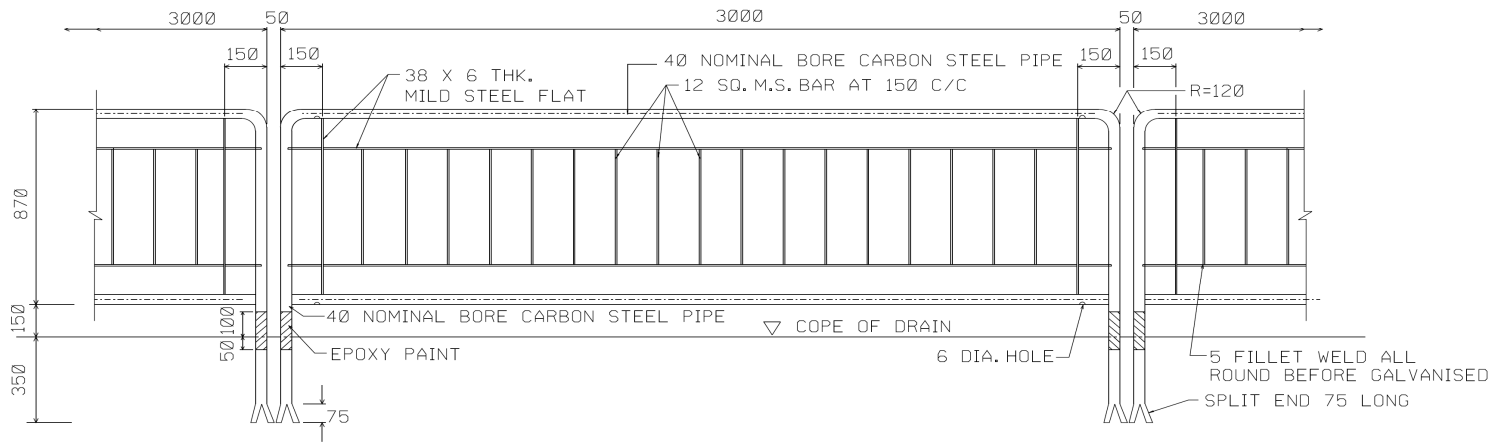

FRONT ELEVATION

NOTES:

1. ALL DIMENSIONS ARE IN MILLIMETRES UNLESS OTHERWISE STATED.
2. ALL JOINTS TO BE 5mm FILLET WELD.
3. MATERIALS
 - a) ALL CARBON STEEL PIPES TO BE LIGHT TUBES CONFORMING TO S.S.17
 - b) ALL STEELS USED ARE TO BE MILD STEEL CONFORMING TO B.S.4360
 - c) ALL GALVANISING TO BE HOT DIPPED GALVANISED COATING CONFORMING TO S.S.117
4. PREPARATION
 - a) ALL STEEL PIPES, FLATS & SQUARES ARE TO BE ASSEMBLED AND WELDED BEFORE GALVANISING
 - b) ALL WELDING SLAGS AND SPLATTERS SHALL BE REMOVED BY CHIPPING OR OTHER MECHANICAL MEANS BEFORE THE ENTIRE ASSEMBLED RAILING IS HOT-DIPPED GALVANISED
 - c) ALL WELDING WORKS SHALL BE CARRIED OUT BY QUALIFIED WELDERS TESTED ACCORDING TO BS 4872
5. PAINTING
 - a) ONE COAT OF APPROVED ETCH PRIMER
 - b) ONE COAT OF APPROVED ZINC CHROMATE PAINT
 - c) ONE UNDERCOAT OF APPROVED OIL BASED PAINT
 - d) TWO TOP COATS OF APPROVED OIL BASED PAINT

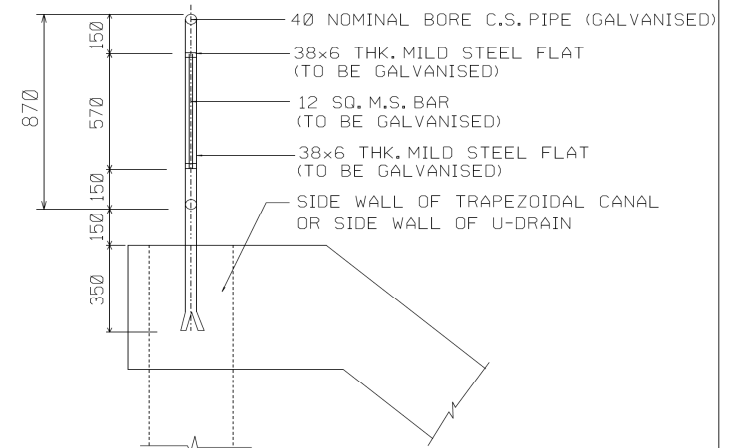

END ELEVATION

DRAWING NO. 6

STANDARD SAFETY RAILINGS

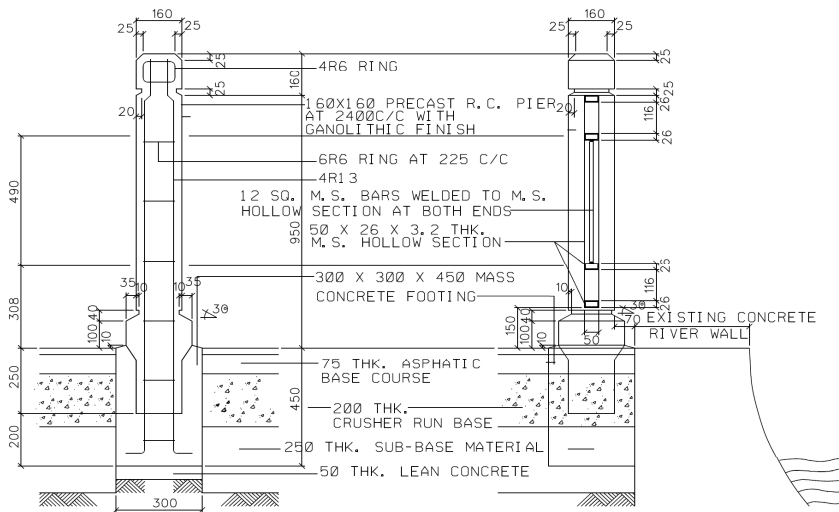

SECTION X - X

SECTION Y - Y

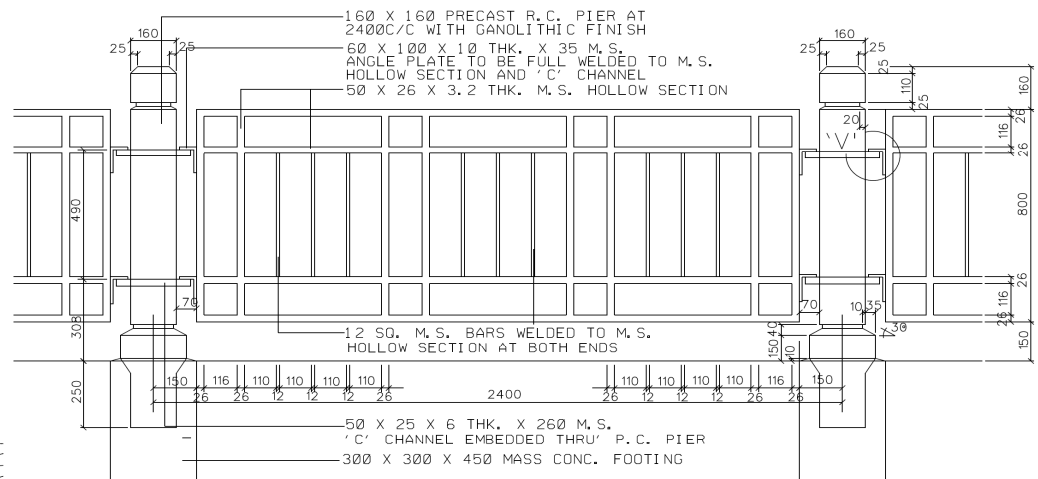

ELEVATION AT 'Z'

60 X 100 X 10 THK. X 35 M.S. ANGLE PLATE TO BE FULLY WELDED TO M.S. HOLLOW SECTION AND 'C' CHANNEL.

50 X 25 X 6 THK. X 260 M.S. 'C' CHANNEL EMBEDDED THRU' P.C. PIER

NOTE : ALL STEEL MEMBERS FOR RAILING SHALL BE GALVANISED & PAINTED TO PAINTING SPECIFICATIONS AS OUTLINED IN NOTE NO.5 OF DRAWING NO. 6

10 DIA. M.S. DOWEL TO BE FULLY WELDED TO M.S. ANGLE PLATE

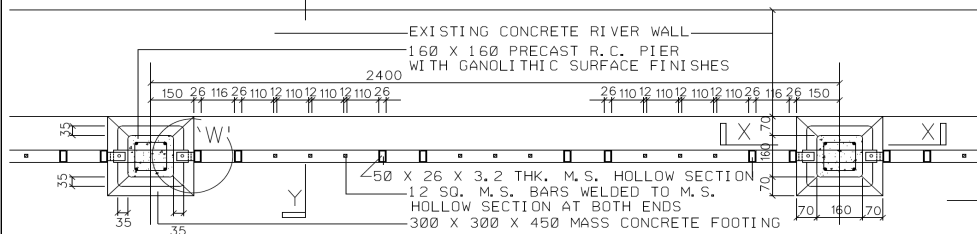

PLAN OF M.S. RAILING (TYPE C)

NOTES

1. ALL DIMENSIONS ARE IN MILLIMETRES UNLESS OTHERWISE STATED.
2. ALL MASS CONCRETE SHALL BE GRADE 25.
3. ALL REINFORCED CONCRETE SHALL BE GRADE 40.
4. ALL LEAN CONCRETE SHALL BE GRADE 15.
5. MILD STEEL AND HIGH TENSILE STEEL REINFORCEMENTS SHALL CONFORM TO S.S.2.
6. MAIN REINFORCEMENTS SHALL HAVE A CLEAR COVER OF 50mm FROM THE BASE OF EARTH FACE AND A CLEAR COVER OF 70mm FROM THE BASE OF WATER FACE.
7. FABRIC MESH REINFORCEMENTS SHALL CONFORM TO S.S. 32.
8. ALL PRECAST CONCRETE SHALL BE GRADE 30.
9. ALL GALVANISING TO BE HOT DIPPED GALVANISED COATING CONFORMING TO S.S.117.
10. SPECIFIED CHARACTERISTIC STRENGTH OF HIGH YIELD STEEL BAR (T) IS 460 N/mm².
11. SPECIFIED CHARACTERISTIC STRENGTH OF PLAIN ROUND MILD STEEL BAR (R) IS 250 N/mm².

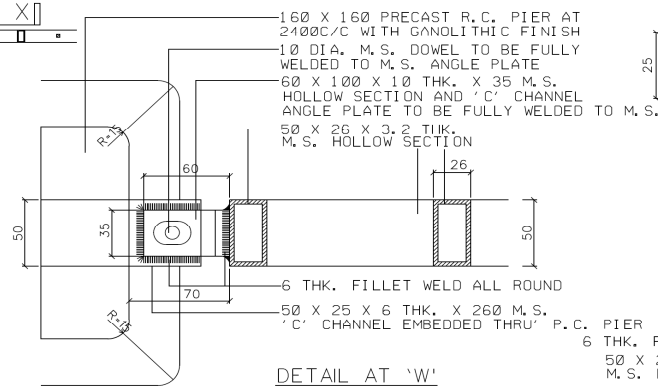

DETAIL AT 'W'

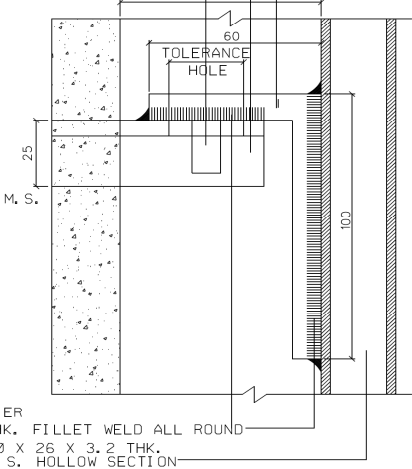

DETAIL AT 'V'

DRAWING NO. 7A

APPROVED SPECIAL RAILINGS

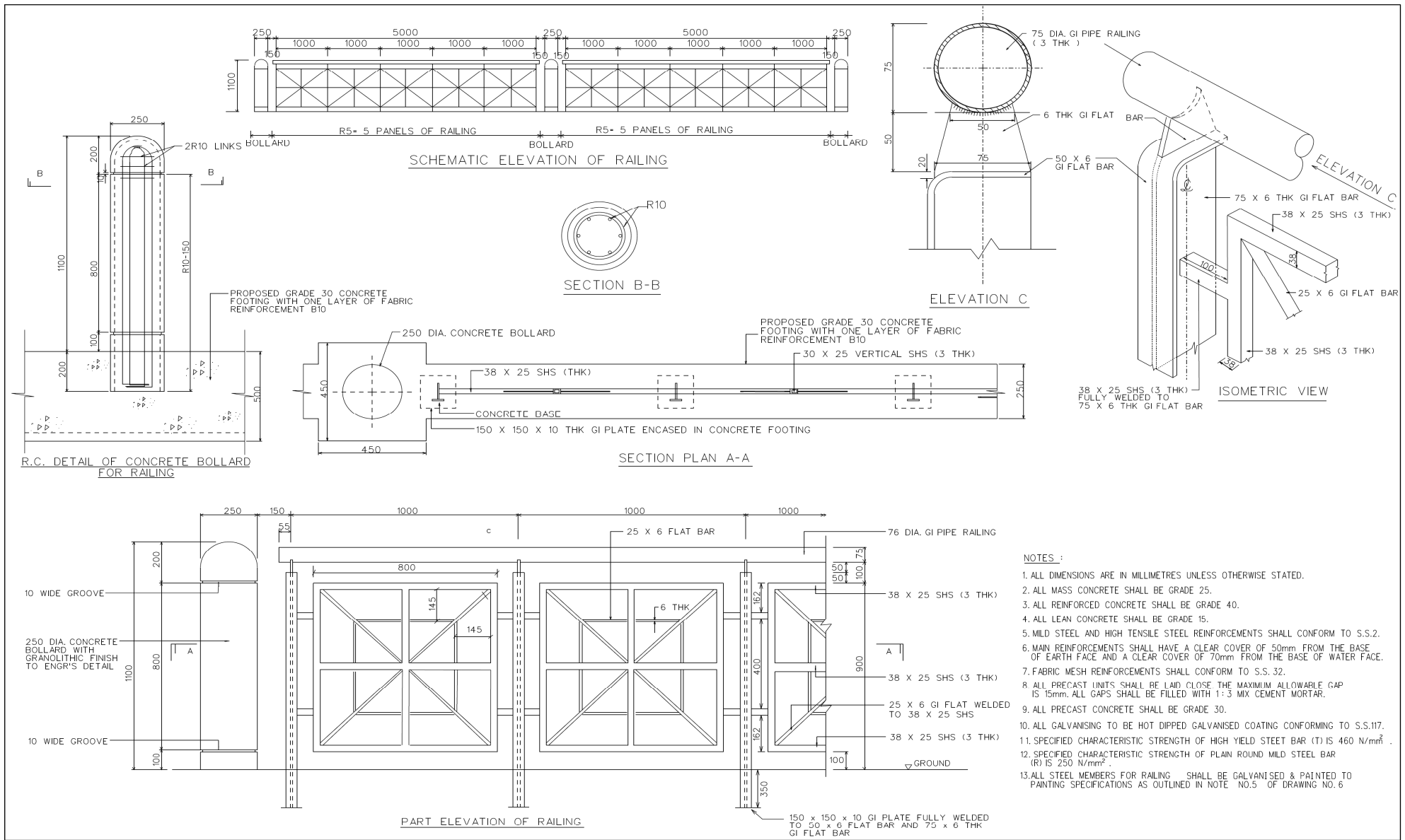

- NOTES :**
1. ALL DIMENSIONS ARE IN MILLIMETRES UNLESS OTHERWISE STATED.
 2. ALL MASS CONCRETE SHALL BE GRADE 25.
 3. ALL REINFORCED CONCRETE SHALL BE GRADE 40.
 4. ALL LEAN CONCRETE SHALL BE GRADE 15.
 5. MILD STEEL AND HIGH TENSILE STEEL REINFORCEMENTS SHALL CONFORM TO S.S.2.
 6. MAIN REINFORCEMENTS SHALL HAVE A CLEAR COVER OF 50mm FROM THE BASE OF EARTH FACE AND A CLEAR COVER OF 70mm FROM THE BASE OF WATER FACE.
 7. FABRIC MESH REINFORCEMENTS SHALL CONFORM TO S.S.32.
 8. ALL PRECAST UNITS SHALL BE LAID CLOSE THE MAXIMUM ALLOWABLE GAP IS 15mm. ALL GAPS SHALL BE FILLED WITH 1:3 MIX CEMENT MORTAR.
 9. ALL PRECAST CONCRETE SHALL BE GRADE 30.
 10. ALL GALVANISING TO BE HOT DIPPED GALVANISED COATING CONFORMING TO S.S.117.
 11. SPECIFIED CHARACTERISTIC STRENGTH OF HIGH YIELD STEEL BAR (T) IS 460 N/mm².
 12. SPECIFIED CHARACTERISTIC STRENGTH OF PLAIN ROUND MILD STEEL BAR (R) IS 250 N/mm².
 13. ALL STEEL MEMBERS FOR RAILING SHALL BE GALVANISED & PAINTED TO PAINTING SPECIFICATIONS AS OUTLINED IN NOTE NO.5 OF DRAWING NO. 6

DRAWING NO. 7B

APPROVED SPECIAL RAILINGS

This drawing shows typically the Earth Control Measures at construction site.
 Details of the Earth Control Measures are to be designed by Qualified Erosion Control Professional (QECP).

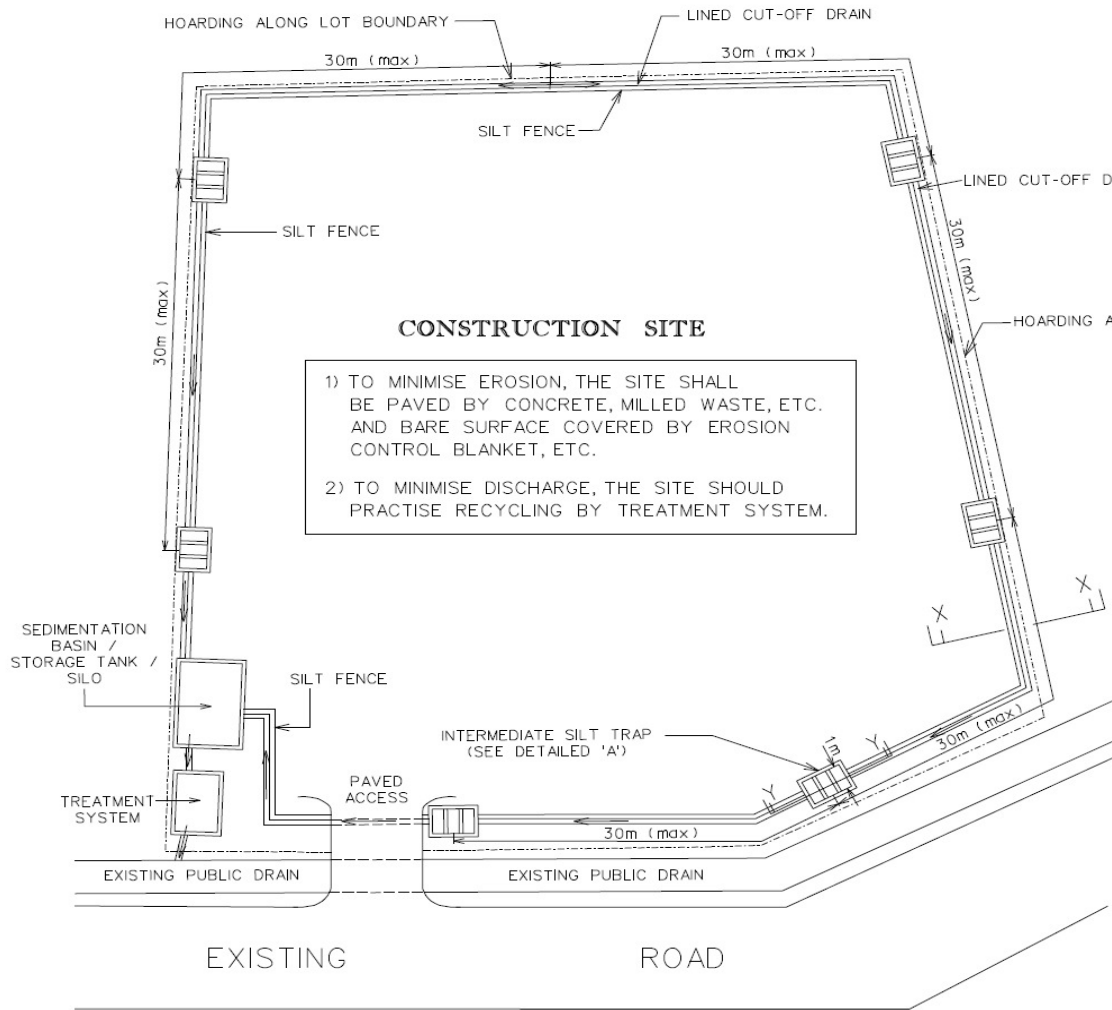

- CONSTRUCTION SITE**
- 1) TO MINIMISE EROSION, THE SITE SHALL BE PAVED BY CONCRETE, MILLED WASTE, ETC. AND BARE SURFACE COVERED BY EROSION CONTROL BLANKET, ETC.
 - 2) TO MINIMISE DISCHARGE, THE SITE SHOULD PRACTISE RECYCLING BY TREATMENT SYSTEM.

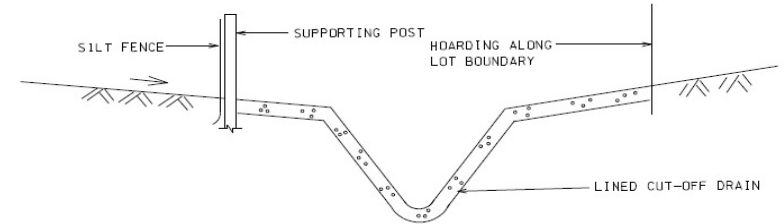

SECTION X - X
N.T.S

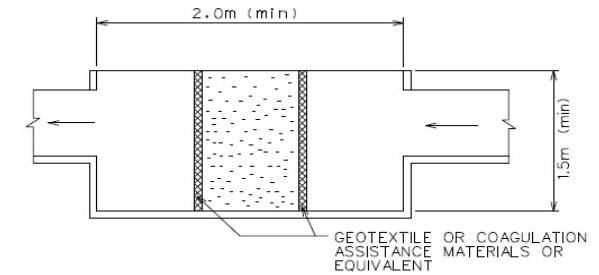

SECTION Y - Y
DETAIL 'A'
N.T.S

- Treatment System:**
- (1) If a site has suitably sized storage pond / tank and treatment system, the rainfall to be considered is equivalent to 80 mm/m² of the construction site.
 - (2) As an illustration, for 0.5 ha (5,000 m²) site, the storage pond / tank should contain a minimum of 400 m³ and the treatment system should have a minimum capacity of 40 m³/hr, as outlined in clause 6.3.8(B). To reduce the storage and treatment capacity, a site can reduce the erodible or bare surface by adopting measures as outlined in Clause 6.3.8(A).
 - (3) Please refer to Earth Control Measures (ECM) website www.pub.gov.sg/ECM for details of Earth Control Measures

This drawing shows schematically the drainage facilities and minimum structural requirements. Details of the structural, geotechnical and foundation systems are to be designed by Qualified Persons.

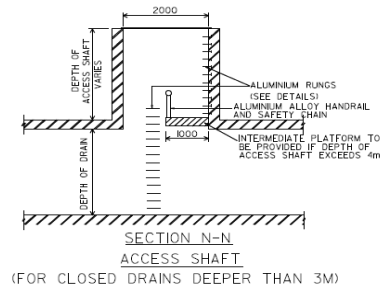

SECTION N-N
ACCESS SHAFT
(FOR CLOSED DRAINS DEEPER THAN 3M)

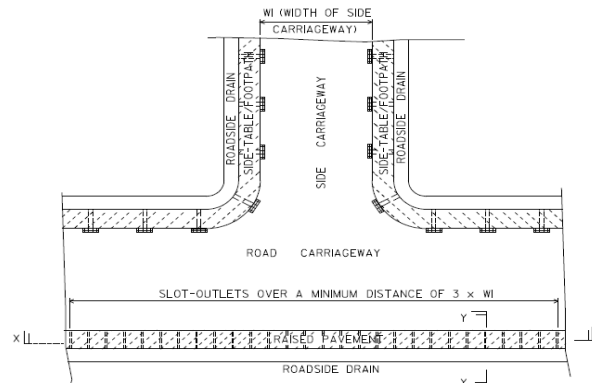

SCHEMATIC PLAN VIEW AT T-JUNCTION OF ROADS

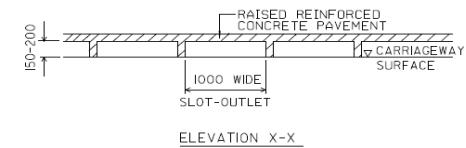

ELEVATION X-X

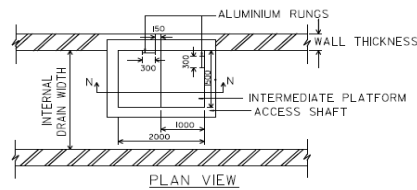

PLAN VIEW

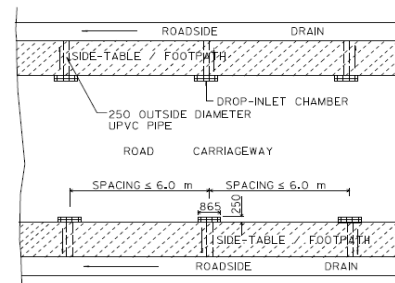

SCHEMATIC PLAN VIEW

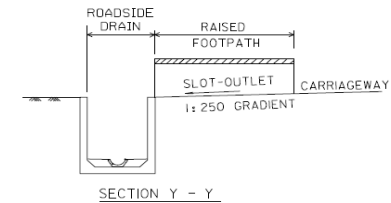

SECTION Y - Y

Notes:

- 1 ALL DIMENSIONS ARE IN MILLIMETRES UNLESS OTHERWISE STATED.
- 2 ALL CONCRETE TO BE MINIMUM GRADE 20 UNLESS OTHERWISE STATED.
- 3 THE STRUCTURAL DETAILS OF THE REINFORCED CONCRETE PAVEMENT SHALL BE DESIGNED TO WITHSTAND PEDESTRIAN LOADINGS IN ACCORDANCE WITH LAND TRANSPORT AUTHORITY'S REQUIREMENTS
- 4 SLOT-OUTLETS ARE TO BE PROVIDED FOR A MINIMUM DISTANCE OF 3 TIMES THE SIDE CARRIAGEWAY WIDTH OVER THE "BLIND" EDGE OF THE T-JUNCTION WHERE THE T-JUNCTION IS LOCATED AT A LOWER LEVEL THAN THE CONNECTING SIDE CARRIAGEWAY ALTERNATIVELY, DROP-INLET CHAMBERS ARE TO BE PROVIDED AT INTERVALS OF 3.0m OVER A MINIMUM DISTANCE OF 3 TIMES THE SIDE CARRIAGEWAY WIDTH.